

# Implementer's Guide to Lime Stabilization for Septage Management in the Philippines



**USAID**  
FROM THE AMERICAN PEOPLE





**Copyright © 2015**

*This report has been prepared for the United States Agency for International Development (USAID), under the Water Security for Resilient Economic Growth and Stability (Be Secure) Project, Contract No. AID-492-C-13-00015.*

# **Implementer's Guide to Lime Stabilization for Septage Management in the Philippines**



# CITY OF TACLOBAN SEPTAGE MANAGEMENT PLANT

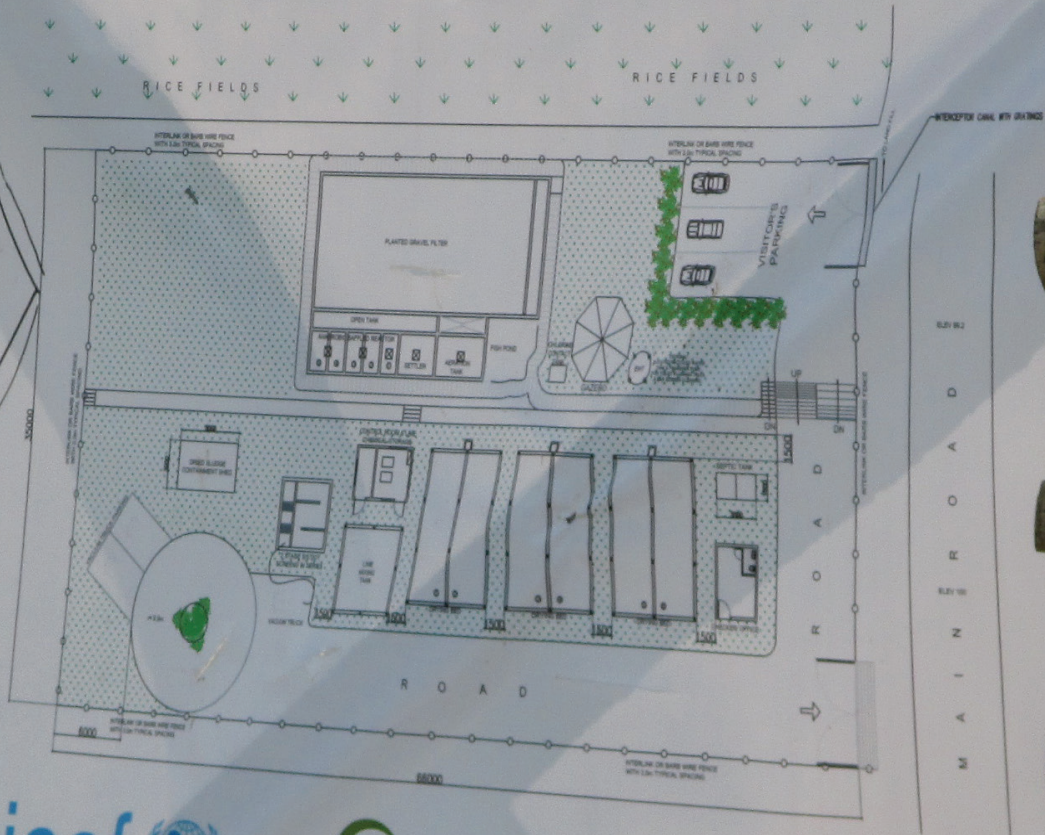

THIS  
WAY



**unicef**  
unite for children

  
**Samaritan's Purse**  
INTERNATIONAL RELIEF

**USAID**  
FROM THE AMERICAN PEOPLE







# Contents

<b>1</b>	<b>Introduction</b>	<b>3</b>
	Who is this Manual for?	4
	The Purpose of this Manual	5
	How to Use this Manual	5
	Definitions	6
	Is Lime Stabilization a Good Option for Me?	8
<b>2</b>	<b>What is Lime Stabilization?</b>	<b>13</b>
	Lime Stabilization Theory and Practice	14
	The Science of Lime Stabilization	14
<b>3</b>	<b>Four-Step Process</b>	<b>19</b>
	Pre-Treatment	22
	Stabilization	23
	Biosolid Processing	24
	Secondary Treatment	27
<b>4</b>	<b>Designing Your Facility</b>	<b>33</b>
	Determining the Volume	33
	Sizing of Key Components	35
	Sizing of Constructed Wetlands	38
	Guarding Against Climate Change Impacts	39
	Worksheet	40
<b>5</b>	<b>Choosing Your Site</b>	<b>43</b>
	How Much Land Do I Need?	43
	Finding a Suitable Piece of Land	43
	Parcel Suitability Checklist	44
	Develop a Site Plan Sketch	45
	Worksheet	46



<b>6</b>	<b>Operations and Maintenance</b>	<b>49</b>
	Components of a Good O&M Program	49
	Operating your Lime Stabilization Facility	50
	Health and Safety	56
	Maintaining your Lime Stabilization Facility	57
<b>7</b>	<b>Short-Term Planning for Disasters</b>	<b>61</b>
	Lime Stabilization in Trenches – A One-Step Process	62
	Two-Step Process Using a Reactor Pit and Sand Drying Beds	63
	Step-by-Step Process for Emergency Lime Stabilization Systems	64
	Compliance During Disasters	65
<b>8</b>	<b>Regulatory Considerations</b>	<b>69</b>
	Department of Public Works and Highways	69
	Department of Health	69
	Department of Environment and Natural Resources	69
	Local Ordinances on Septage Management	69
<b>9</b>	<b>References</b>	<b>70</b>



# List of Figures and Tables

## Figures

1. Septage	6
2. Components of successful septage management programs	7
3. Components of permanent septage treatment systems	19
4. Hydraulic gradient using gravity flow	20
5. Layout of a permanent lime stabilization septage treatment system	21
6. Trash rack	22
7. Grit chamber	23
8. Lime stabilization reactor tank	23
9. Underdrain system of a sand-drying bed	24
10. Sand drying beds	24
11. Sludge drying beds	24
12. Sand drying bed with underdrain details	25
13. Silt over sand	26
14. Anaerobic baffled reactor under construction	27
15. Subsurface flow constructed wetlands	28
16. Tablet chlorinator and liquid chlorinators	29
17. Natural disinfection pond	30
18. Layout for the planned lime stabilization system in Tacloban City	44
19. Initial site plan for a hypothetical septage treatment facility	45
20. Quick couplers	51
21. Discharge from reactor tank	52
22. Hand mixing of septage	53
23. Checking the pH using a hand-held pH meter	53
24. Imhoff cones	53
25. Trench system for lime stabilization	62
26. Reactor pit	63
27. Stabilized sludge in a makeshift drying bed	65

## Tables

1. Comparison of Different Septage Treatment Technologies	9
2. Average BOD Reduction of Various Technologies	20





# Acknowledgments

The USAID Be Secure Project is grateful all who were involved in the creation of this Implementer's Guide to Lime Stabilization for Septage Management in the Philippines. This guide is a result of collaboration and input from a dedicated team and group of advisors.

First of all, our deepest appreciation to the Department of Public Works and Highways, League of Cities of the Philippines, and the Philippine Association of Water Districts.

Special thanks to Mr. Jonathan Hijada, City Environment and Natural Resources Officer, Tacloban City, and Mr. Carlito Santos, President/CEO of Uniclean Enviro Construction Corporation. We also thank Engr. Antonio Garcia, Engr. Ryan Orillo, Engr. Ferdinand Carandang and Engr. Ruby Jean Sibulo of Maynilad Water Services for their cooperation and support in the filming of the instructional videos on septage management.

Finally, to the men and women working hard to promote and expand the National Sewerage and Septage Management Program (NSSMP) in the Philippines, thank you for your dedication.

# Message from LCP



Improved sanitation through proper wastewater treatment creates a healthy workforce and clean environment. These propel economic growth in cities. However, for cities to develop viable wastewater treatment projects, they need technical information on effective, low-cost approaches and technologies. A fairly simple, affordable first step is to develop a septage management program using lime stabilization technology.

This manual will be helpful for cities as it features a step-by-step procedure for establishing a septage management program using a combination of hydrated lime slurry and sand drying beds as the main treatment process. The manual captures the experience of Tacloban City, which employed the system following Typhoon Yolanda to treat septage and sewage collected from evacuation centers and other temporary shelters.

The **League of Cities of the Philippines (LCP)** appreciates the support provided by the **United States Agency for International Development (USAID) Water Security for Resilient Economic Growth and Stability (Be Secure) Project** in the development of a viable alternative towards effective and safe water management. LCP looks forward to working together to promote proper sanitation and sustainable development for the benefit of the Filipino people.

A handwritten signature in black ink, appearing to read 'Herbert M. Bautista', written over a white background.

**Mayor Herbert M. Bautista**  
Quezon City





# Message from USAID



The **United States Agency for International Development (USAID)** is pleased to partner with the **League of Cities of the Philippines (LCP)** and the **Philippine Association of Water Districts (PAWD)** to advance the development of improved sanitation in the Philippines. This manual supports implementation of the National Sewerage and Septage Management Program (NSSMP), which DPWH developed in compliance with the Clean Water Act.

Improved sanitation protects human health and the environment, which are essential to achieve inclusive, sustainable and resilient growth. Through the implementation of the NSSMP, the Government of the Philippines is working to substantially increase the number of sanitation projects nationwide and increase the number of people with access to sanitation. In addition to the health and environmental benefits, effective sanitation programs can ultimately be an additional source of water, once treated, which will increasingly be an important benefit as climate change continues to affect communities and water stress becomes a reality.

USAID has supported Philippine national and local government agencies to improve sanitation for many years, initially, through the Local Initiatives for Affordable Wastewater Treatment (LINA) Project, Philippine Sanitation Alliance (PSA) Project, Environmental Cooperation-Asia (ECO-Asia) Program, Environmental Governance (EcoGov) Project, the Philippine Water Revolving Fund, and now via the Water Security for Resilient Economic Growth and Stability (Be Secure) Project. This support has resulted in increased access to improved sanitation for many Filipino families.

Through the Be Secure Project, USAID is assisting with the training of staff of DPWH and Local Water Utilities Administration, supporting the nationwide NSSMP rollout campaign in select regions, and developing this manual to help implementers prepare septage management programs. The U.S. Government looks forward to its continued partnership with the Philippine Government to achieve the goals set out under the NSSMP, including improvement of water quality and the protection of public health through increasing access to improved sanitation.

A handwritten signature in black ink, appearing to read "Gloria Steele".

**Gloria D. Steele**  
**Mission Director**  
**USAID/Philippines**



**USAID**  
FROM THE AMERICAN PEOPLE

# Message from PAWD



On behalf of the **Philippine Association of Water Districts (PAWD)**, the national umbrella organization of more than 500 water districts in the country, I laud the **United States Agency for International Development (USAID) Water Security for Resilient Economic Growth and Stability (Be Secure) Project** for crafting a Septage Management Manual that will guide local implementers to jump-start their septage management program using a simple and low-cost system.

Undoubtedly, water scarcity and lack of sanitation pose serious health and economic risk to everyone, especially to the poor and the disadvantaged.

In the Philippines, studies show that although the population using improved water and sanitation has increased on a yearly basis, there is still much room for improvement, particularly in the rural areas where water districts are the leading service providers.

Hence, the Be Secure Project's Septage Management Manual will be an indispensable tool for local governments and water districts in order to build and operate septage management systems that will address various problems on sanitation and treatment and disposal of wastewater.

As water districts, we are mandated not only to provide potable, adequate, and affordable water but also to provide effective sanitation services to our respective concessionaires. We are in a great position to be the primary agents of change that will contribute to improved health and environmental conditions in the municipalities and ultimately in the whole country.

I urge the frontrunners in the water industry to take full advantage of this guidebook and be part of the global effort of conserving and protecting the essential resource of life and good health.

A handwritten signature in black ink, appearing to read 'Pablito S. Paluca', written over a horizontal line.

**Pablito S. Paluca**  
**President**





# About the NSSMP

More than 90% of the sewage generated nationwide is not treated properly. This results in economic losses exceeding Php 78 billion per year, and 55 deaths per day. The Clean Water Act requires the Department of Public Works and Highways (DPWH) to lead the preparation of the **National Sewerage and Septage Management Program (NSSMP)** as part of the integrated framework for water quality management.

The NSSMP targets LGUs, water districts and private service providers as the major program implementers. They have the mandate to address sewerage and septage, and the greatest ability to design, implement and manage projects.

The goal of the NSSMP is to improve water quality and protect public health in urban areas of the Philippines by 2020. The objectives are to enhance the ability of local implementers to build and operate wastewater treatment systems for urban centers and promote the behavior change and supporting environment needed for systems to be effective and sustainable.

## **NSSMP Targets**

- By 2020, all LGUs have developed septage management system and the 17 highly urbanized cities have developed sewerage systems;
- By 2020, approximately 43.6 million people have access to septage treatment facilities and about 2.3 million will have access to sewerage treatment facilities;
- By 2020, Php 26.3 billion has been invested in sanitation improvement projects; and
- By 2020, about 346 million kilograms of biochemical oxygen demand (BOD) is diverted from the environment per year as a result of sewerage and septage management projects.







# Instructional Videos

Three short instructional videos were developed as an accompanying tool to this publication. The videos are useful as a supplementary learning tool for local governments, water districts and the private sector who plan to develop a septage management program using lime stabilization.

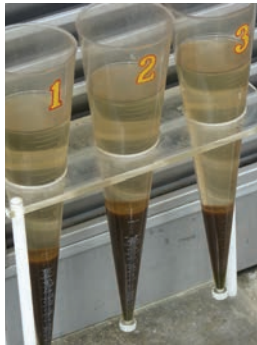

## Conducting a Jar Test for Evaluating Sand Drying Bed Media



[http://youtu.be/6VQ8Kjy5P\\_s](http://youtu.be/6VQ8Kjy5P_s)



## How to Make a Lime Slurry



<http://youtu.be/3PZsxXK-il4>



## How to Use a Hand-held pH Meter



<https://youtu.be/YwfWR2woWI4>



# Acronyms

<b>ABR</b>	Anaerobic Baffled Reactor
<b>BOD</b>	Biochemical Oxygen Demand
<b>DENR</b>	Department of Environment and Natural Resources
<b>DPWH</b>	Department of Public Works and Highways
<b>EMB</b>	Environmental Management Bureau
<b>EPA</b>	(United States) Environmental Protection Agency
<b>LGU</b>	Local Government Unit
<b>NSSMP</b>	National Sewerage and Septage Management Program
<b>O&amp;M</b>	Operations and Maintenance
<b>PPE</b>	Personal Protective Equipment
<b>RTA</b>	Rapid Technical Assessment
<b>USAID</b>	United States Agency for International Development







# Introduction

# 1

Implementer's Guide to  
Lime Stabilization for  
Septage Management  
in the Philippines











# Introduction

Republic Act 9275 or the “Clean Water Act” is the national law that aims to protect the country’s water bodies from pollution. This law also mandates the implementation of sewerage and septage management programs in the country. Unfortunately, in the Philippines only about 7% have access to sewerage or wastewater treatment programs, and while more than 80% of households have septic tanks, most are unmaintained.<sup>1</sup> Most septic tank desludgers also dispose of septage in the wrong way.

Under normal circumstances, septage accumulates in septic tanks and needs to be regularly collected, treated and disposed of, to protect our health and the environment. But because only a few cities have any programs that guide the collection, treatment and disposal of raw sewage, consequently raw sewage ends up in rivers, streams and empty fields, creating hazards for anyone exposed to it. During and after disasters, fecal sludge or raw sewage from evacuation centers and temporary relocation sites also needs to be properly managed. The lack of substantial wastewater treatment services lead to poor environmental, sanitation, and health conditions. Untreated wastewater spreads disease-causing bacteria and viruses, makes water unfit for drinking, threatens biodiversity, and deteriorates the overall quality of life.

So how do you go about developing a septage management program that is both cost-efficient and relatively easy to implement? One practical approach that you can follow to implement a good septage management program is using lime stabilization to kill the pathogens that make septage hazardous to our health and dispose of it in an environmentally-friendly manner. Some of the text in this manual is about best practices, and some is about science, but most of it is our advice on how to best go about setting up a functional and sustainable program. Our first piece of advice? Don’t worry, you are not alone.

Local government units (LGUs) just beginning to implement a new septage management program may wish to phase in the program over time. Lime stabilization can be done as a first phase following a disaster and perhaps serve the public and commercial sectors. In the next phase, a municipal or city-wide program to desludge all septic tanks on a regular schedule using treatment technologies besides lime stabilization could be established. Phasing infrastructure should be carefully considered at the beginning since it has impacts on the overall project design and cost.

We created this manual in response to increasing interest in lime stabilization among LGUs that we work with in the Philippines. We hope our experience will give you some ideas on how you can set up a program for your city or municipality as required by national government regulations.

This is a “how to” guide that you can follow to implement a good septage management program using lime stabilization to kill the pathogens in the septage.

<sup>1</sup> *Joint Monitoring Programme for Water Supply and Sanitation (JMP) 2012 Report (WHO/UNICEF); Water Environment Partnership in Asia*



# Who is this Manual for?

This manual is for implementers – the person on the ground who makes things happen. You may be:

- **A municipal or city government staff person**, such as the City or Municipal Environmental Officer (CENRO or MENRO), engineer, planner, or health officer tasked by the mayor with setting up a septage management program.
- **A water service provider**, such as a water district, mandated to provide sanitation services to its customers.
- **A disaster preparedness specialist**, responsible for managing fecal sludge and septage following natural or manmade disasters.
- **A private sector service provider** interested in providing septage collection or treatment services as a business opportunity.

If you are the implementer this manual is for you!

## Self-Test

Still not sure if this manual is for you? Here is a short quiz that might help. Read each statement and answer either “yes” or “no.”

STATEMENT	YES	NO
We (my municipality/city) are ready to manage septage during and after disasters.		
We have identified a parcel of land that is accessible and on high ground where we can manage septage following a disaster.		
We have stocked emergency equipment to run the septage treatment facility immediately after the disaster.		
We have established a roster of trained workers who will manage the septage treatment facility during and after the disaster.		
We are developing a permanent septage management program for our entire city or municipality.		

If you have answered “yes” to all of these statements, your city or municipality is very advanced. We hope that you still find the remainder of the manual interesting if not useful. If you have answered “no” to any of these statements, we encourage you to use this manual to help you achieve your goals. So let’s get started. Your first step is to learn how to use this manual.

# The Purpose of this Manual

This manual will:

- Serve as your step-by-step guide to developing a successful community-wide septage management program using lime stabilization, which is a low-cost and innovative technology;
- Help you establish emergency response capabilities for managing septage and fecal sludge during and after a disaster;
- Educate you on the best practices and latest low-cost methods of septage management; and
- Increase your confidence that you can do this by breaking down the required activities into a step-by-step process.

As with any technology, there are best practices that can be utilized to improve performance, reduce costs, and make the process safer for the community and the workers engaged in the practice. This is the focus of this manual.

## How to Use this Manual

To help you navigate this manual, the following icons are used to present key information:

This manual contains practical information you need to set up a functional septage management program using lime stabilization. Checklists are provided to help you keep track of critical tasks, and we give examples to show you how other LGUs have implemented septage management programs. Short videos are available to demonstrate certain tasks.



*This icon indicates a **step-by-step process**. Look for it and follow the steps to complete a given task.*



*Resources where you can find more information.*



*Practical guidance. Sound practices and recommendations vetted by our team of experts.*



*Operations. Much of effective septage management relies on the work of the operator. We will point out key activities as we move along.*



*Workers. As with operators, we will point out areas where a trained and able workforce will help you achieve positive results.*



*The tanker truck driver, to identify where coordination with the trucking operation is especially useful.*



*We use this icon to indicate tasks where **personal protective equipment (PPE)** is required. Not just when it is convenient or when the boss is around, but **ALL THE TIME!** This is of critical importance to protect workers from lime, which can cause blindness if it gets into someone's eye.*

# Definitions

Before we get too much further, we would like to discuss some terms with you, just to make sure we all have a common understanding. These are not in alphabetical order.

## Septic Tank

A tank, typically underground, in which sewage is collected. Over time, bacteria consume and break down the waste. It should have a closed bottom, at least two compartments, be accessible for desludging and have access ports and vents.

Let's face it! Few of the septic tanks in use in the Philippines look like the proper tank shown in Figure 1. Many septic tanks are improperly installed under buildings, have open bottoms, have no access ports (manholes) or vents, are located too far away (or located too far down a narrow alley) for the desludger's hose to reach. These conditions can affect the ease and efficiency of the desludging operations, and even the strength and characteristics of the septage once it is collected.



Before developing a septage management program, assess the septic tanks in your community for size, construction and ease of access. This will tell you on average how much septage you will be able to collect on a day-to-day basis. Section 4.1 includes information on how to do a rapid technical assessment.

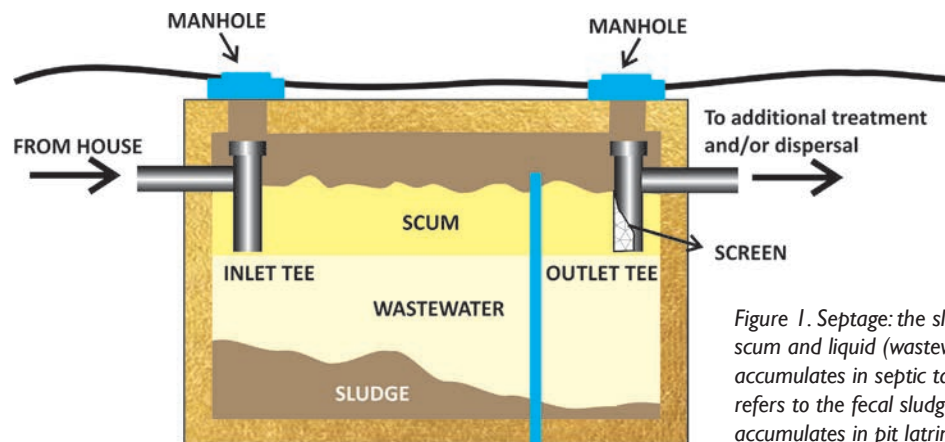

Figure 1. Septage: the sludge, scum and liquid (wastewater) that accumulates in septic tanks. Also refers to the fecal sludge that accumulates in pit latrines.

## Septage

Septage refers to the waste materials stored in a septic tank. However, in this manual, we will often use the word septage to also include raw sewage that is collected from portable toilets and evacuation centers after a disaster. Notice the layers in Figure 1? Septic tanks contain solids at the bottom, liquid effluent in the middle, and scum on top. The liquid effluent should slowly flow out of the tank and be further treated before being discharged to the environment. The solids (septage) should be removed, treated and disposed of properly. When the solid sludge layer gets too thick the water runs out immediately, and you may have a problem flushing your toilet. At this point, the septic tank can't do its job – decomposition works best when the solids fill up less than half of the tank.

Once the septage is collected and properly treated, it can be added to agricultural soil to make it more fertile, or be used to make other valuable products.



# Septage Management Program

A septage management program is an organized program to regularly collect, treat and dispose of septage by **water districts, LGUs, or the private sector**, or a combination of these.

Effective septage management programs collect septage from septic tanks using vacuum trucks, moving from barangay to barangay on a regular scheduled basis. Often each septic tank is desludged once every three to five years. These programs are enhanced through local ordinances and promotion campaigns that improve participation and willingness to pay for services. Usually a small fee is added to the water bill or property tax bill, or some similar mechanism of making collections is created to help fund the program. For example, Dumaguete City Water District adds a fee of Php 2 per cubic meter of water used onto the water bill, and San Fernando City charges Php 600 per house per year through the property tax bill. People tend to find this much more affordable than to pay all at once to desludge their septic tank! It is appealing to implementers as well because they achieve cost recovery in about 4 ½ years, after which the fees can be used to expand services, or fund septic tank improvement grants for the urban poor, or generate profits if it is a private sector run program.

**Regulatory framework** – an enabling environment that includes training, access to financing, and policies such as a local septage management ordinance. There are many laws in the Philippines that regulate wastewater. A local ordinance brings them all together for local compliance and enforcement.

**Promotion campaigns** – the campaigns that inform residents about the program and increase their motivation to comply and pay for the service. The USAID 10-Step Promotion Toolkit can be used to develop a campaign ([www.10step-toolkit.org](http://www.10step-toolkit.org)).

**Infrastructure and investment** – vacuum trucks and low-cost treatment systems, and improved septic tanks at buildings.

Here are the three components of successful septage management programs:

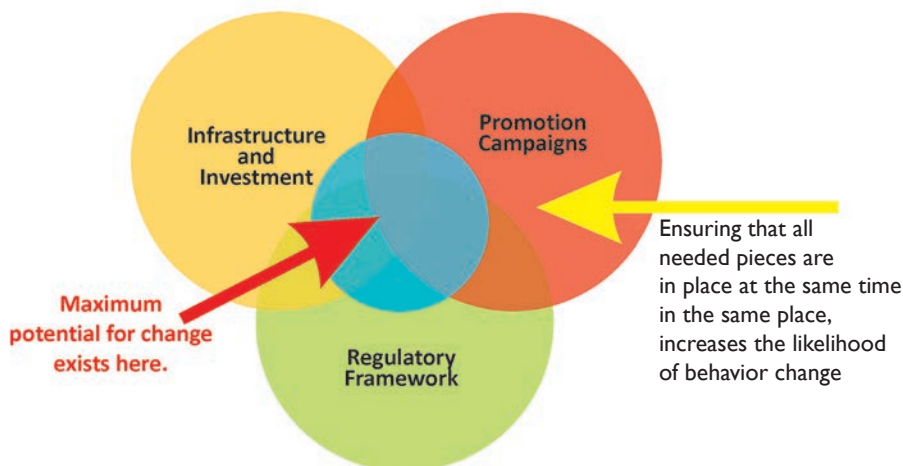

Figure 2. The link between infrastructure, regulatory framework, and promotion campaigns in achieving sustainable environmental improvement (Lynne Cogswell, AECOM, 2009).

## Lime Stabilization

A low-cost technology for treating septage by adding hydrated lime to it. This is not a new technology and it is used all over the world because it is a low-cost and effective option, and relatively easy to set up and manage.

There are many technologies out there and this manual is not intended as an endorsement for lime stabilization. However, it is very useful for at least the first phase of a septage management program and for dealing with fecal sludge and septage that has to be collected from evacuation centers following a disaster. It ranks high on cost-benefit analyses of treatment technologies (see Table I on the next page).

## Is Lime Stabilization a Good Option for Me?

Let's look at some of the other septage treatment technologies for comparison. There are many available technologies. For the purposes of this manual, we can divide them into four main groups:

- **Natural systems.** Sewage lagoons or ponds, and constructed wetlands, also known as reed beds. They require a large piece of land but are relatively low-cost to install and easy to operate;
- **Hybrid systems.** Usually uses a mechanized system for dewatering and a natural system for treating the effluent and biosolids. It requires less land than a full natural system and is relatively low-cost;
- **Mechanized systems.** Require a small piece of land, but are more expensive to build and operate and require highly skilled operators; and
- **Chemical treatment** (including lime stabilization). Relatively low-cost, requires a medium-sized piece of land and moderately trained workers.

Each has advantages and disadvantages as can be seen in Table I.

LGUs with large areas of low-cost land might consider sewage lagoons, while those with very limited land area might consider mechanized systems. Frequently, local governments are starting out with lime stabilization systems, not only for their disaster preparedness needs, but also for initial phases of permanent programs. Even if your permanent septage treatment program uses a mechanized system, lime stabilization may still be useful for treating septage contaminated with chemicals, solvents, or petroleum hydrocarbons from commercial sources.

**Table 1. Comparison of Different Septage Treatment Technologies**

Type of Treatment	Location	Facility Cost / Area Requirement				Remarks
		Treatment Capacity per day				
		5 m <sup>3</sup>	10 m <sup>3</sup>	15 m <sup>3</sup>	30 m <sup>3</sup>	
Natural treatment system using anaerobic lagoon, facultative lagoon, maturation pond, reed bed	Dumaguete, Negros Oriental	Php 3 M 3,000 m <sup>2</sup>	Php 5.5 M 6,000 m <sup>2</sup>	Php 7.5 M 9,000 m <sup>2</sup>	Php 13 M 10,000 m <sup>2</sup>	<ul style="list-style-type: none"> <li>• Large space requirement</li> <li>• Low cost</li> <li>• Minimal electricity required</li> <li>• No chemicals</li> </ul>
Hybrid system using anaerobic baffled reactor, upflow anaerobic sludge blanket, facultative lagoon, maturation pond	San Fernando, La Union	Php 3 M 3,000 m <sup>2</sup>	Php 5.5 M 6,000 m <sup>2</sup>	Php 7.5 M 9,000 m <sup>2</sup>	Php 13 M 10,000 m <sup>2</sup>	<ul style="list-style-type: none"> <li>• Large space requirement</li> <li>• Low cost</li> <li>• Minimal electricity required</li> <li>• No chemicals</li> </ul>
Mechanized system and chemical treatment	Baliuag, Bulacan	Php 20 M 400 m <sup>2</sup>	Php 20 M 500 m <sup>2</sup>	Php 22 M 600 m <sup>2</sup>	Php 35 M 750 m <sup>2</sup>	<ul style="list-style-type: none"> <li>• Minimal space requirement</li> <li>• Expensive investment, operation and maintenance</li> </ul>
Chemical treatment using lime stabilization, drying bed, anaerobic baffled reactor, facultative pond	Typhoon Yolanda-affected areas	Php 2 M 600 m <sup>2</sup>	Php 3 M 1,000 m <sup>2</sup>	Php 5 M 1,200 m <sup>2</sup>	Php 8 M 1,500 m <sup>2</sup>	<ul style="list-style-type: none"> <li>• Medium cost due to minimal chemical and electrical usage</li> </ul>



*Always perform a cost-benefit analysis before choosing a technology. Include capital costs for the infrastructure, land requirements, costs for operations and maintenance, and skill level of the operators who you will utilize to run the system. When you don't know a cost item, estimate it or seek input from local contractors.*



*Fecal Sludge Management, by Linda Strande, is a textbook on septage management. It is a great reference and has extensive sections on technologies. Download it for free here: [http://www.sandec.ch/fsm\\_book](http://www.sandec.ch/fsm_book).*









# What is Lime Stabilization?

## 2

Implementer's Guide to  
Lime Stabilization for  
Septage Management  
in the Philippines

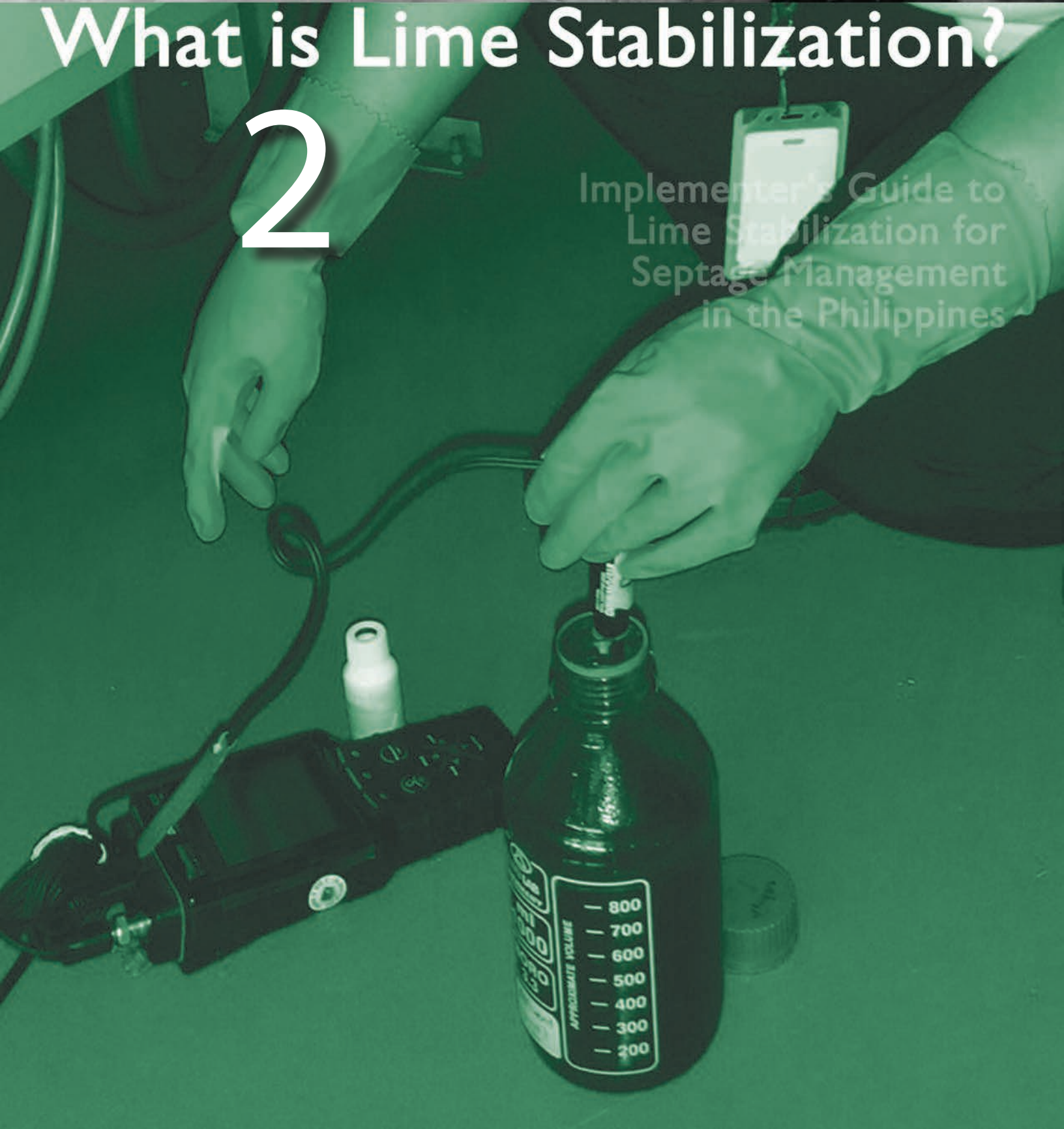







# What is Lime Stabilization?

The lime stabilization process treats septage by mixing it with a chemical called hydrated lime, also known as calcium hydroxide ( $\text{CaOH}_2$ ). This helps kill pathogens and condition the septage to reduce odors and limit the re-growth of pathogens.

Hydrated lime is available in many areas of the Philippines, with prices varying depending on the location. In some areas it is about Php 300 per 40 kilogram bag.

Some quick facts:

- If you use agricultural lime (calcium carbonate) and not hydrated lime (calcium hydroxide), the process will not work;
- If you use quick lime and not hydrated lime, you or your workers may get injured because quick lime can react violently, splatter and even cause fires! Hydrated lime may have some quick lime in it so it is important to follow the safety recommendations in this manual;
- Operators need to always wear PPE when they are handling hydrated lime to minimize risk of injury;
- These systems can be mechanized or manually operated. Manual systems are labor intensive;
- Even for larger septage management systems that use other technologies, lime stabilization is useful for septage loads contaminated with chemicals such as petroleum hydrocarbons (fuel oil or gasoline);
- Lime stabilization requires mixing proper amounts of hydrated lime into the septage. The process does not work if the amount is wrong. This is checked with a hand-held pH meter; and
- Even when conducted properly, lime stabilization does not result in complete disinfection. Additional treatment steps may be required for final treatment and proper disposal of the remaining liquid effluent and biosolids into the environment.

## Different Types of Lime

### Agricultural lime:

Calcium carbonate ( $\text{CaCO}_3$ ) is crushed limestone used to improve uptake of plant nutrients.

### Quick lime:

Calcium oxide ( $\text{CaO}$ ) is used in making mortar.

### Hydrated lime:

Calcium hydroxide ( $\text{CaOH}_2$ ) is the only lime suitable for lime stabilization of septage.

# Lime Stabilization Theory and Practice



According to EPA, septage is processed through lime stabilization by elevating the pH to 12 or above for 30 minutes.

When septage reacts with hydrated lime, the pH goes up. The pH scale is 1 – 14 where one is the most acidic and 14 is the most basic. Lime stabilization begins to occur when the pH is higher than 11. When the pH reaches 12, maximum pathogen reduction can be achieved. US Environmental Protection Agency (EPA) research indicates that about 10 - 20 kilograms of hydrated lime is typically enough to process 4,000 liters of septage, depending upon the four factors presented below.

The four determining factors for stabilizing septage with hydrated lime are:

- Amount of lime used per volume of septage (concentration);
- Strength and purity of the hydrated lime;
- Mixing; and
- Strength of the waste.

Historically, lime has been used to treat wastewater from open pit latrines, wastewater treatment plants, and even leachate ponds at solid waste facilities. In 1978, EPA popularized the technology for septage treatment through their publication *Full Scale Demonstration of Lime Stabilization*.

## The Science of Lime Stabilization

The reaction that occurs breaks down the organic matter in the septage, effectively eliminates odors and prevents re-growth of many pathogenic bacteria. Note that:

- Pathogen reduction increases as pH increases, but consistently high pathogen reduction occurs only after pH 12 is reached;

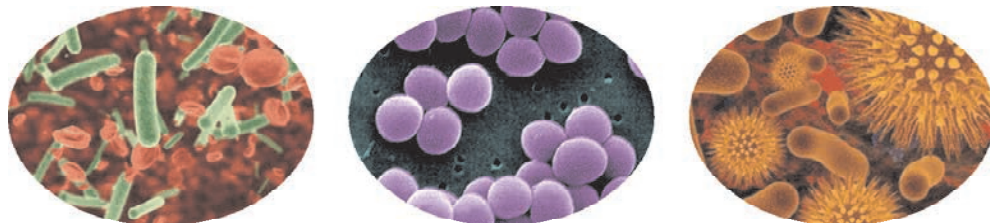

- The amount of lime required to reach pH 12 can vary widely for septage (0.19 to 0.5 kilograms of lime/kilogram of dry solids). Checking with a pH meter is mandatory to achieve good results.

In 2007, the technology was used in the Philippines as a pilot project in San Fernando City, La Union. Laboratory results indicated that the technology worked well. In the following years, some other LGUs began experimenting with lime stabilization and it was used following several natural disasters to treat waste from evacuation centers.

## ADVANTAGE

This study showed how all of the physical components of lime stabilization facilities should be configured (more on that topic in following sections). The research concluded that:

- Lime stabilized septage can be dried to about 25% solids in as little as 6 days if applied to the sand beds in 16-20 centimeter layers;
- The technology is effective even when the septage is contaminated with fuel and oil, although contaminated septage should be treated separately from non-contaminated septage; and
- Alternative methods of mixing with air bubbles or mechanical paddles improves results.

## DISADVANTAGE

We talked about the advantages, now be aware of the disadvantages of lime stabilization:

- **Local availability of hydrated lime.** Hydrated lime is generally available throughout the Philippines, but there may still be delivery issues and higher costs in your location;
- **Continuous cost of lime.** In addition to paying personnel, LGUs will need funds to continually buy lime. This cost can be recovered through fees to make it more sustainable;
- **Health and safety issues.** Hydrated lime can be dangerous, so worker training, strict use of use of PPE and monitoring is required;
- **Can be labor intensive.** This is especially true when there is no mechanization; and
- **Lime application does not result in complete disinfection.** Secondary treatment and disinfection is still required before effluent or biosolids can be disposed of into the environment.



*Decentralized Systems Technology Fact Sheet. – Septage Treatment and Disposal:*

<http://nepis.epa.gov/Exe/ZyPDF.cgi/200044F8.PDF?Dockkey=200044F8.PDF>

*Here is another good fact sheet:*

[http://www.nesc.wvu.edu/pdf/WW/publications/eti/Septage\\_tech.pdf](http://www.nesc.wvu.edu/pdf/WW/publications/eti/Septage_tech.pdf)



## EPA Full Scale Demonstration of Lime Stabilization

*Conclusion:* “Lime stabilization facilities can be constructed and operated at lower capital and annual operation and maintenance costs than comparable anaerobic digestion facilities, and present an attractive alternative either as a new process or to upgrade existing sludge handling facilities.”

Download the full text at:

<http://nepis.epa.gov/Exe/ZyPDF.cgi/20006CQZ.PDF?Dockey=20006CQZ.PDF>



*Our early field work in San Fernando City in La Union Province showed that it can be hard to get to pH 12, especially with hand mixing with a paddle. Even at pH 11, the stabilization process is well under way. If there is no pH meter, mix the hydrated lime at 20 kilograms per 4,000 liters of septage. Mix for 30 minutes and let sit for as long as possible (up to 24 hours). Since you may not have achieved full pathogen reduction, additional treatment may still be required such as air drying on site for 4 - 6 months, or composting.*



*Another important study was conducted by EPA specifically on lime stabilization for use as an alternate septage treatment technology.*

<http://nepis.epa.gov/Exe/ZyPDF.cgi/9100SNQA.PDF?Dockey=9100SNQA.PDF>





# Four-Step Process

1  
2  
3  
4

Implementer's Guide to  
Lime Stabilization for  
Septage Management  
in the Philippines

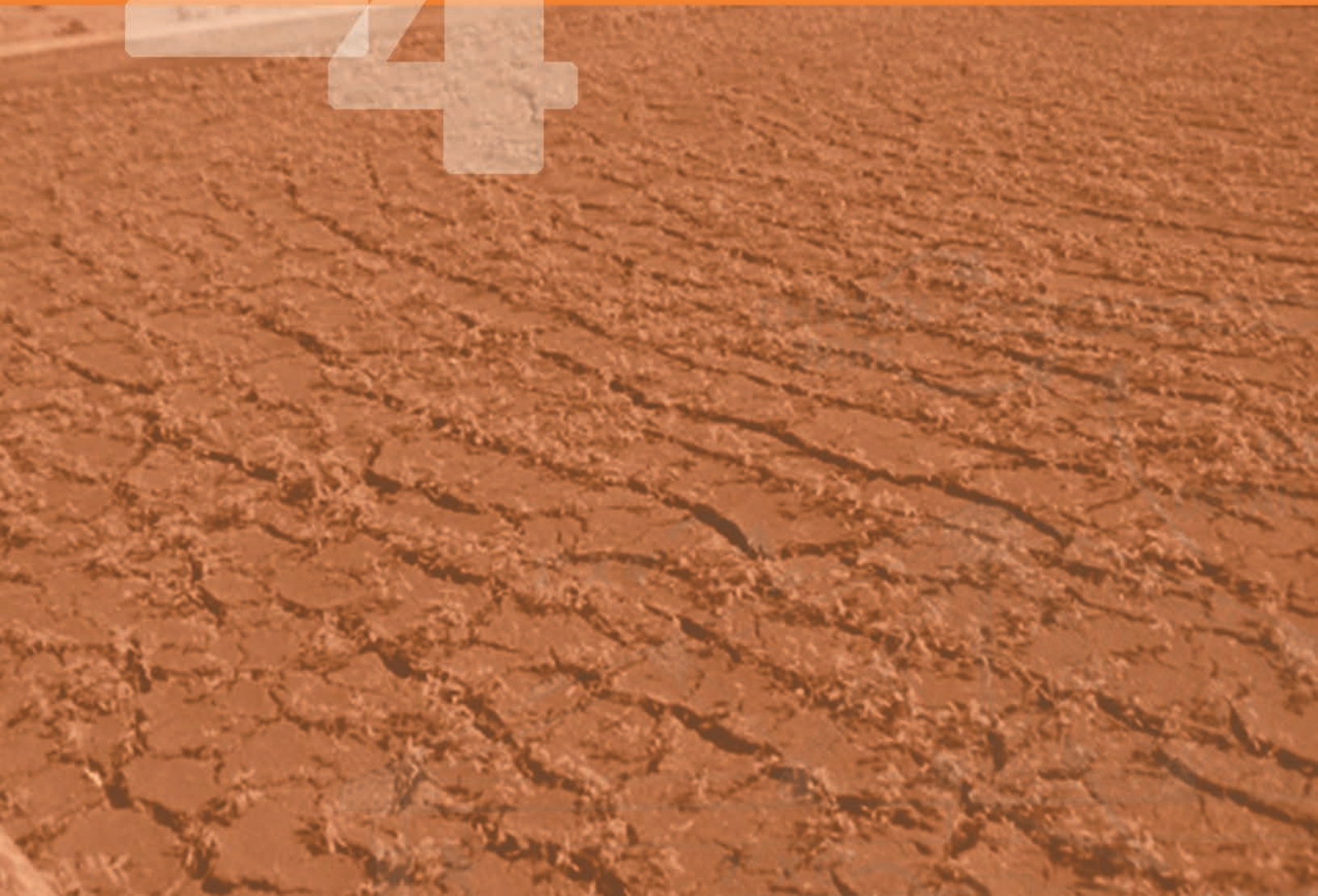







# Four-Step Process

There are four main steps in a permanent lime stabilization system (Figure 3):

1. **Pre-treatment** – screens and grit chambers;
2. **Stabilization** – reactor tanks;
3. **Biosolid processing** – sand drying beds for dewatering and drying of biosolids; and
4. **Secondary treatment** – effluent treatment and disinfection.



1

Screens and grit chambers



2

Reactor tank where lime and septage are mixed



3

Sand drying beds with underdrains



4

Constructed wetland for secondary treatment



Septage is highly variable in strength. Biochemical oxygen demand (BOD), which is a measurement of wastewater strength, can range from 1,000 milligrams/liter to over 20,000 milligrams/liter and the solids can range from 3% to 20% in raw septage. It is difficult to obtain representative samples of septage so it is okay to estimate. Table 2 below compares the BOD reduction capacity of the various technologies described in this section. We will use these again in the section on facility sizing.

**Table 2. Average BOD Reduction of Various Technologies**

Pre-treatment BOD (mg/l)	Technology	Post-treatment BOD (mg/l)
5,000 +	Trash screen	5,000 +
5,000 +	Grit chamber	5,000 +
5,000 +	Reactor tank	2,500
2,500	Sand drying bed	500
500	Anaerobic baffled reactor	200
200	Wetlands or lagoon	50
50	Disinfection	50 or less

NOTE: Check with your local DENR representative for discharge requirements in your area, in some cases it may be more stringent than the standard 50 milligrams/liter for BOD.

Figure 4. Hydraulic gradient using gravity flow.

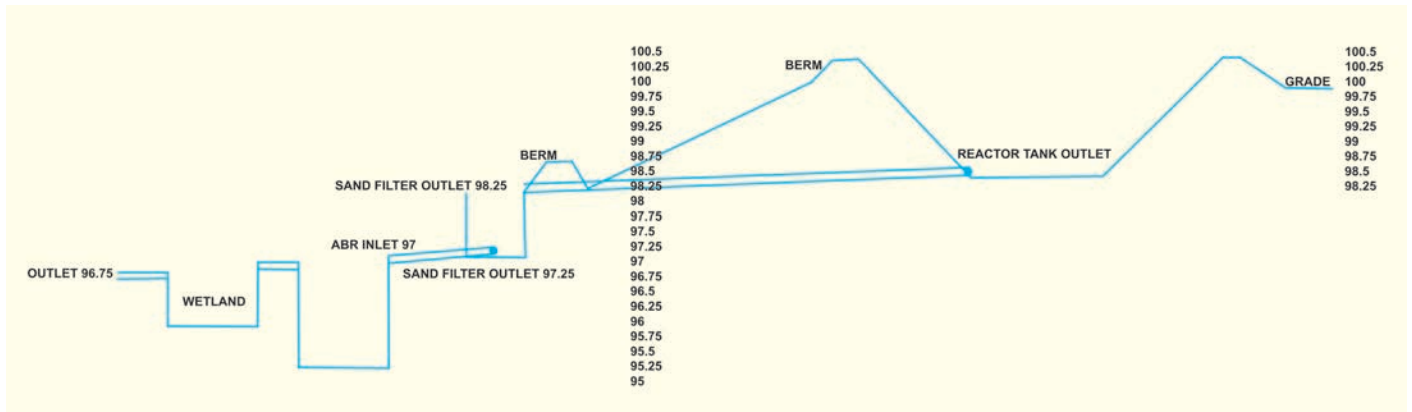

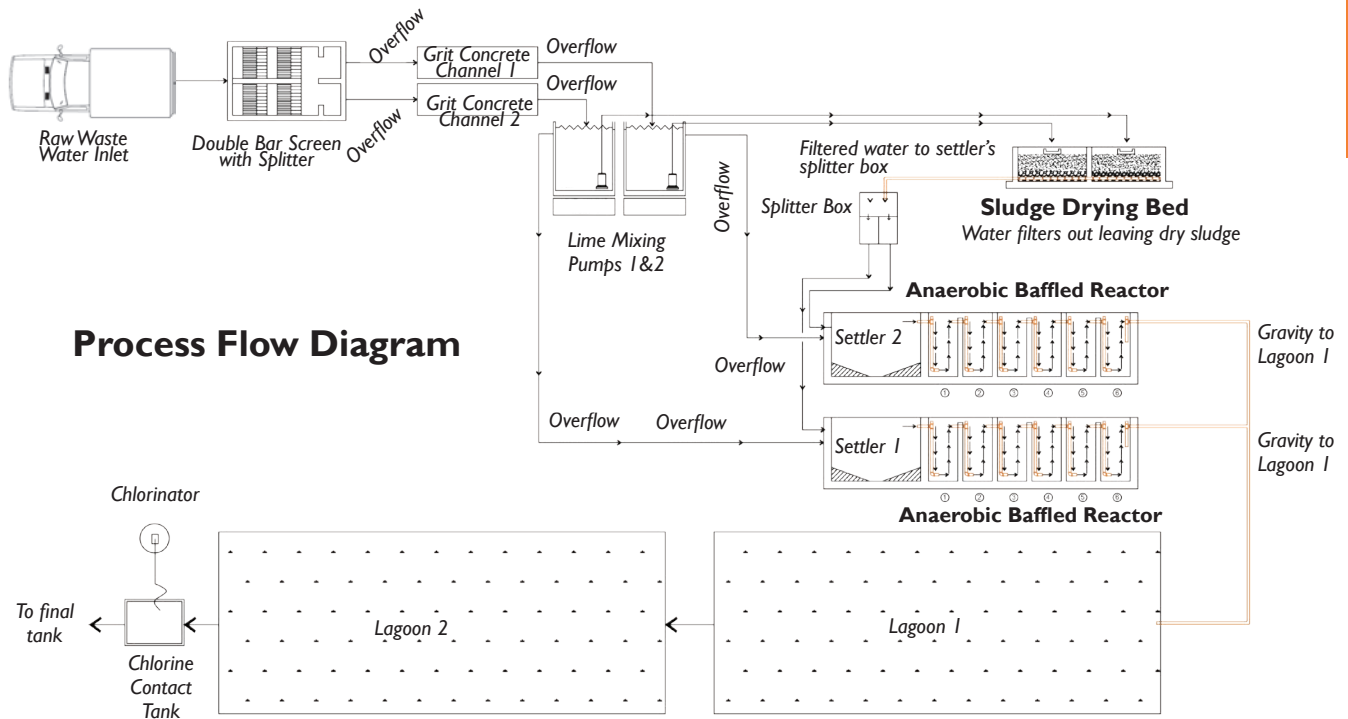

Figure 5. Typical layout of a permanent lime stabilization system.

The treatment facility configuration (Figure 5) should be arranged to maximize gravity flow of wastewater from one treatment process to the next. A site with gently sloping land may be ideal if the only mechanized lifting occurs when the septage is transferred from the truck through the trash screens. The flow dynamics for such a configuration are as follows:

1. Septage is pumped from the truck to the trash screens;
2. Screened septage flows by gravity through the grit chamber to the reactor tanks where it is contained by a closed gate valve;
3. Hydrated lime is added to the septage as a slurry (see procedure described below in the operations and maintenance section);
4. After the lime-septage reaction is complete, the gate valve is opened and the treated septage flows via gravity to a distribution box where a series of valves directs it to the sand drying beds. If the site is too flat, the septage must be transferred manually or using a lift station or pump;
5. Effluent captured in the underdrain pipes flows via gravity to the anaerobic baffled reactor (ABR);
6. Effluent from the ABR flows from the outlet pipe into the lagoon or wetland or lagoon; and
7. The treated effluent then flows through the chlorinator and contact chamber for disinfection, after which it is discharged to the environment.



*If manual transfer is the only option, it must be performed in a hygienic manner using PPE, and buckets and carts that can be operated easily and without contaminating your workers. In emergencies, the pumper truck can be used to transfer treated effluent and biosolids from the reactor pit to the sand drying bed.*

# Pre-Treatment

Pre-treatment includes trash screens and grit chambers.

- **Trash screens.** Designed to remove the large solids often found in septage, which may include garbage, in pieces generally larger than 2.5 centimeters in diameter.
- **Grit chamber.** Designed to remove sand, gravel and other similarly-sized inorganic particles.



*Figure 6. Trash rack constructed out of painted metal. Hinged at one end, the racks are easy to tip collected debris into conveniently located trash bins.*

In a phased system, consider making these large enough to handle the future volume to minimize retrofitting costs later on.

Trash racks or screens can be made locally out of stainless steel, painted metal (Figure 6) or even fiberglass or plastic. The screens shown are placed on a hinge and can be simply tipped up to empty into a waiting receptacle. They are used to remove the larger solids that may end up in septic tanks including rags or other garbage.

Trash racks should have mesh openings of between 2 – 5 centimeters. They should be of light weight but durable construction. Trash racks may be equipped with a tipping device such as a lever or pulley to facilitate easy dumping.

Grit chambers (Figure 7) are required for larger sized facilities but optional for smaller systems.

They are concrete channels designed to slow down the septage flow, which allows sand and gravel (grit) to settle down to the bottom. Frequent removal





Figure 7. Grit chamber at the San Fernando, La Union septage treatment facility.

of grit is required to minimize odors. Grit chambers should be cleaned with rakes and shovels when the level of collected materials reaches 0.2 meters. Removed grit can be dried on-site and then transported to a landfill for disposal.

## Stabilization

Reactor tanks are used for mixing the lime into the septage (Figure 8). They may be earthen pits lined with plastic (polyvinyl chloride or PVC) or other liner material that is impervious to the chemicals and heat generated by the lime-septage reaction. They are typically designed to handle up to three truckloads of septage, ensuring there is at least 0.5 meters between the top of the septage and the top of the tank to prevent overflows.

See Section 6 for instructions on how to add and mix the lime and septage together.



Figure 8. Lime stabilization reactor tank in Tacloban City, Philippines. It is an earthen pit lined with plastic and mixing is done manually.



View the instructional video on how to make a lime slurry from this link:  
<http://youtu.be/3PZsxXK-il4>

# Biosolid Processing

Following stabilization with lime, the treated septage is transferred to the sand drying beds where the solids are separated from the liquid by evaporation and gravity. The underdrains capture the liquid effluent, which should be further treated.

Sand drying beds consist of a layer of sand approximately 0.3 meters thick, which is placed on top of a bed of gravel that houses the underdrain system (Figure 9). The drying beds are installed in blocks that are designed to be operated in parallel. Drying beds should have tent-like covers or permanent roofs to protect them from rain.

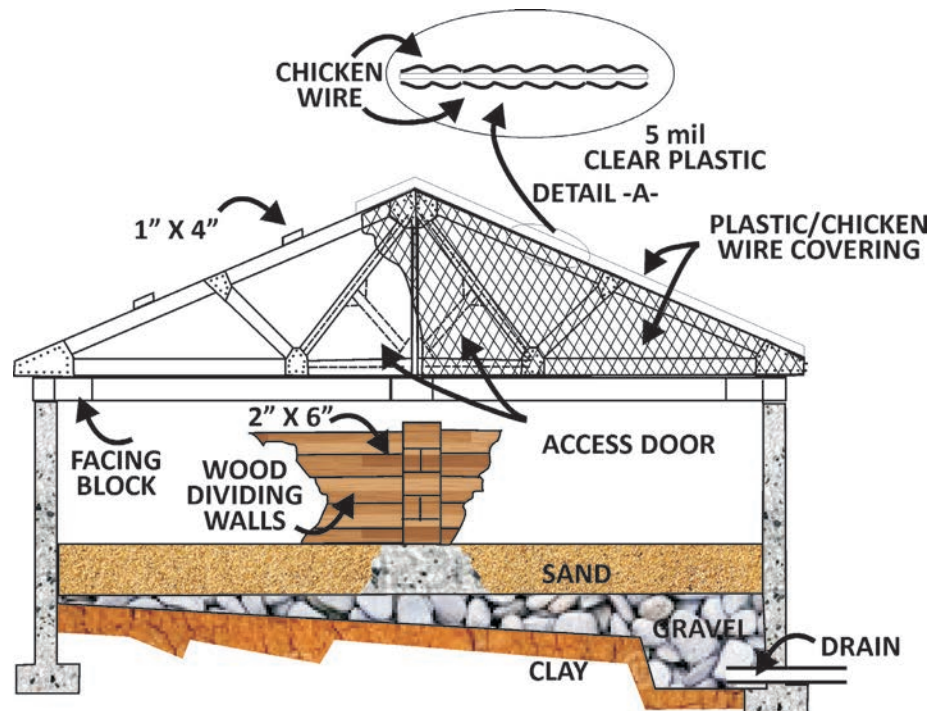

Figure 9. Underdrain system of a sand-drying bed.



Figures 10 and 11. Sand drying beds (left) showing characteristic “cracks” on the sludge surface, indicating sludge is sufficiently dewatered to transfer to bulk biosolids storage area (about 25% dry solids). Sludge drying beds (right) with canvas tents (removed) to shed stormwater which allows dewatering even during rainy season.



## Sand Drying Bed

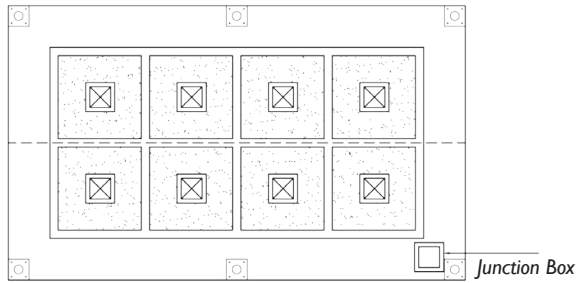

Sand Drying Bed Plan



Sand Drying Bed Perspective

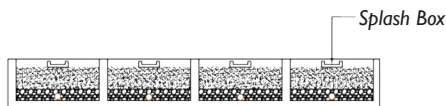

Sand Drying Bed Section

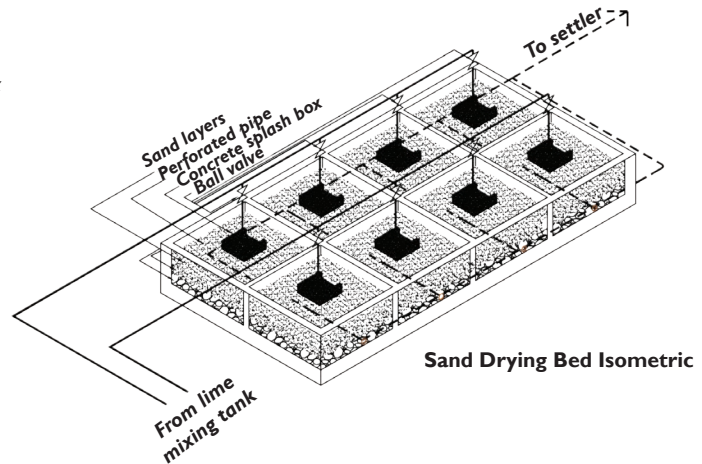

Sand Drying Bed Isometric

Figure 12. Sand drying bed with underdrain details. Set the elevation of the sand drying bed so that gravity flow through the remaining components is possible to avoid the need for pumping.

This drawing (Figure 12) comes courtesy of Carlito Santos through his company, Uniclean Enviro Construction Corp. in Manila. Notice the underdrain piping system that collects the effluent and the dosing piping layout that evenly doses each cell. Lito likes to design drying beds in sections, which allows the operator flexibility in the drying process. In the case of contaminated septage (such as too much fuel oil or restaurant grease), the operator can segregate the batch so as not to contaminate the rest of the biosolids.

Sand drying beds are easy to construct. Use washed sand where possible to limit the amount of small particles that can plug up the filter. For permanent facilities, use hollow blocks to form the walls of the filter beds. Punch holes in the block to install the piping, then fill in the spaces with grout and add a few pieces of rebar for strength.



*Can't find the right site? Keep looking! Check with neighboring LGUs and see if it might be possible to co-manage septage to take advantage of better sites. And don't forget to check with private sector entrepreneurs that might want to start up services.*

### Commercial or Industrial Septage

"Material pumped from commercial facilities such as restaurants, grease traps, gas stations and shopping centers is considered industrial septage. Industrial septage requires special handling, treatment and disposal methods." Lime stabilization is especially good at treating these loads.

Operators can determine if there are high concentrations of chemicals, grease or hydrocarbons by the color, odor and appearance of the septage. Septage with such contaminants should be segregated and treated and dried separately.

*Source: Septage Management in North Carolina, 1995.*



View the instructional video on how to perform a jar test from this link:  
[http://youtu.be/6VQ8KJy5P\\_s](http://youtu.be/6VQ8KJy5P_s)

## Check the Sand – Perform a Jar Test Today!

Sand drying beds work by allowing the liquid portion of the septage to drain through the sand, leaving the solids to air dry. This doesn't work well if there are too many fine particles of silt and clay mixed in with the sand. To determine if there is too much silt and clay, perform a simple jar test using the following instructions. Take a ½ liter jar, fill it halfway with a sample of the sand, add water until the jar is full, then seal. Shake it up and let it sit overnight. The next day, you will see a layer of sand on the bottom, silt and clay in the middle and water on top. Any more than 10% clay and silt on the surface of the sand means the sand should be washed.



Figure 13. See the sample on the right? It is about 30% silt over 70% sand. The sand should be rejected and washed.



## CHECKLIST



### Planning checklist for sand drying beds:

- Sand and gravel should be readily available for delivery to the site. Make sure that the provider understands the sand must be washed and free of clay and silt;
- Be ready to prepare a jar test on each truckload of sand delivered prior to unloading;
- Sand will need to be replaced from time to time, as some of it sticks to the sludge as it dries. There should be an adequate budget for this;
- There should be enough level land to accommodate the beds; and
- The land selected for the sand drying beds should be located at a lower elevation than the outlet from the reactor tank. If not, pumping, manual transfer or a lift station will be required.



# Secondary Treatment

After the sand drying bed procedure, the liquid effluent that was collected needs to be treated to kill the remaining pathogens. This can be done using the following three steps:

- **ABR.** A multi-chambered tank similar to a septic tank designed to partially treat the effluent;
- **Lagoon or subsurface flow constructed wetland.** Treats effluent using naturally-occurring bacteria in ponds or on the roots of plants; and
- **Disinfection tank.** Uses chemicals to ensure that all remaining pathogens are eliminated from the effluent.

You should expect the sand drying bed effluent to still contain up to 500 milligrams/liter of BOD. Anaerobic treatment in an ABR is needed to reduce the BOD to a level where secondary treatment in a lagoon or constructed wetlands is possible.

ABRs are multi-compartment tanks similar to septic tanks that partially treat effluent. They are typically constructed with poured-in-place concrete or concrete hollow blocks that are filled with grout and sealed. Most of the time, horizontal rebars are used for more than 3 layers of hollow blocks, including vertical rebars spaced 0.6 meters apart.

The ABRs should have a 2-day detention time, which should be sufficient to bring the BOD down to under 150 milligrams/liter, which is suitable for lagoon or wetlands treatment.

Lagoons are lined ponds typically 1 to 2 meters in depth. They require a large, level piece of land and are designed with detention times of between 15 and 30 days depending upon the strength of the effluent. There are four types of lagoons or stabilization ponds that may be used for septic treatment:

- **Anaerobic lagoons**, typically greater than 2 meters deep, often receive raw septage. There is no dissolved oxygen found throughout the lagoon and anaerobic bacteria prevail;
- **Facultative lagoons**, typically 1.5 to 2 meters deep, are characterized by having a zone near the surface where some dissolved oxygen is present, and an anaerobic zone near the bottom of the pond. Aerobic, facultative and anaerobic bacteria are present;
- **Aerobic lagoons**, typically less than 1 meter deep, have dissolved oxygen throughout the pond and aerobic bacteria prevail; and
- **Aerated lagoons**, which receive mechanical aeration through bubblers or mixers.

Often facultative lagoons with 2 meter depths are followed by aerobic lagoons that are 1 meter deep to achieve treatment and some disinfection.

Figure 14. Anaerobic baffled reactor under construction.



See the picture in Figure 14? It shows an ABR under construction. Notice the elevation of the tank relative to the houses. The vent for the ABR will need to be higher than roof level to minimize complaints about odor. A large diameter (15 cm) vent pipe painted black works best. If your septage facility is near homes, you can build an odor eliminator made of broken sea shells to address any odor issues (basically just a basket of crushed seashells sitting over the vent pipe. Give it a try!). Especially good smelling plants like ilang ilang, sampaguita or even dama de noche may also help reduce the odor.

Constructed wetlands (Figure 15) may contain a free water surface (surface flow wetlands) or the effluent may be contained completely within a layer of gravel which is covered by soil (subsurface flow wetlands). Constructed wetlands are lined and gravel-filled basins that are about 1 meter deep with a slight horizontal incline to keep the water flowing. They are equipped with inlet and outlet structures that allow the operator to vary the water depth in the basin. Wetland plants are placed in the gravel media, and the microbes on their roots consume the organic matter in the effluent. Constructed wetlands for septage effluent should have a minimum of 3 days detention time to achieve treatment.

### Emergent Macrophyte Treatment System with Horizontal Subsurface Flow

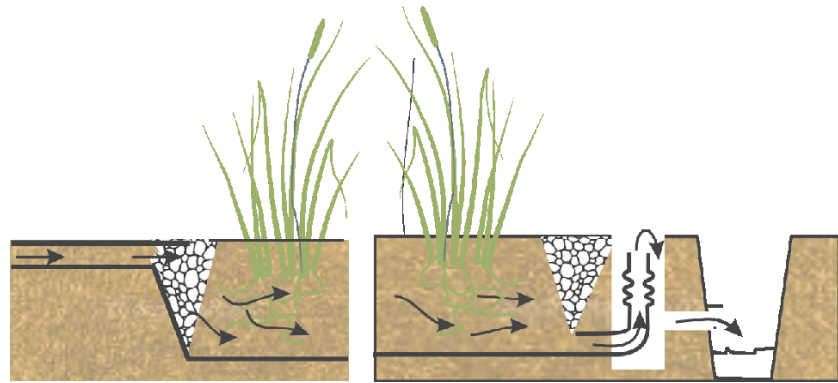

Figure 15. Subsurface flow constructed wetlands using a horizontal flow design.





Following treatment in either a lagoon or constructed wetland, the effluent must be disinfected. This is done either using a disinfection pond (which requires a large amount of space) or a chlorinator and contact chamber, which requires much less space.

Typically, disinfection of secondary effluent is achieved through a dose of 2 milligrams/liter of chlorine as  $\text{Cl}_2$ . Mix thoroughly and maintain a contact time of 20 minutes to ensure proper disinfection in tropical or subtropical environments. For colder environments, such as Baguio or other upland areas, a minimum contact time of 30 minutes is required.

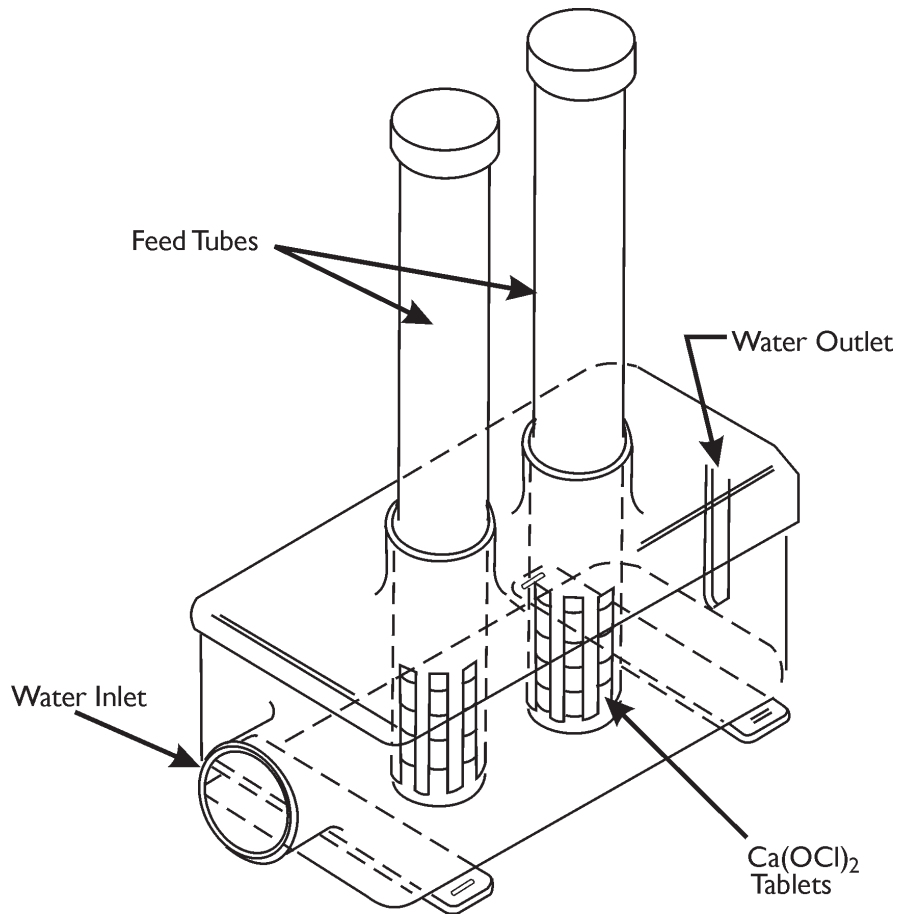

Figure 16. Tablet chlorinator (above) uses chlorine tablets that are placed in the feeder and impart chlorine to the effluent as they dissolve. Liquid chlorinators (right) are applicable to larger flows and require more maintenance than tablet feeders, but are also low cost and easy to operate.



A disinfection pond (Figure 17) is shallow enough that sunlight can penetrate the entire water column. It is typically less than 1 meter in depth and with a minimum detention time of 3 days. They can work very well except when there are too many cloudy or rainy days in a row. Research indicates that the growth of algae can also help kill pathogens. While this is a potential benefit, algae in the discharge effluent can choke natural drainage systems and surface water leading to eutrophication and other problems. Algal blooms (a term used for rapid growth of algae usually in the summer months) can often be physically removed using hand-operated rakes, screens or nets. The removed algae is a good source of nitrogen and can be added to compost to produce a soil amendment useful for agriculture.



*Figure 17. This natural disinfection pond at Dumaguete City's septage treatment facility serves as an indicator pond where fish are used to demonstrate the purity of the water.*



volume

$$\frac{V}{Q} = \text{size of filter}$$

waste strength  
variability

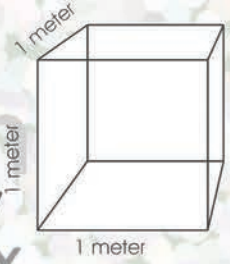

ABR size = design flow x 60% x  
detention time

# 4 Designing your Facility

Implementer's Guide to  
Lime Stabilization for  
Septage Management  
in the Philippines









# Designing your Facility

## Determining the Volume

To design your system and decide how much land you need, you first need to figure out your daily flow, or how much septage you will need to treat per day. To make reasonable estimates, we recommend you conduct a rapid technical assessment (RTA). Here are some factors to consider:

**Volume** of septage to be treated daily (average);

**Variability** or fluctuation by day or season;

**Waste strength** is the concentration of pollutants in the septage such as organic matter, chemicals or other substances.

## Rapid Technical Assessments

If you are developing a new septage management program, you can use the RTA to figure out the daily flow, number of trucks needed to collect the septage, and the size of the treatment facility.

Septic tanks vary widely in the Philippines. The RTA is your chance to find out the average size of the septic tanks in your community and their accessibility (how easy it will be to desludge them). You can probably do the RTA in a few days and gather the following information:

- The average size of the residential, commercial, and institutional septic tanks in the coverage area; and
- The accessibility of the septic tanks and pits for desludging.



### *San Fernando, La Union Experience*

*In 2009, an RTA was conducted by barangay health workers and area plumbers and engineers. They formed teams that gathered enough data in three days to determine the size of the city's septage management program.*



## Step-by-Step Process for the RTA

If you are planning to develop an LGU-wide septage management program, first gather information from the LGU planning office about the number of households and businesses to estimate the total number of septic tanks, and then randomly choose those to visit (set appointments with the owners to increase efficiency). At each location, do the following:

- Step 1:** Locate the septic tank and determine if there are proper access ports and vents;
- Step 2:** Ask the owner if they know the size and volume of the septic tank and if has a closed or open bottom;
- Step 3:** Measure distance from tank access port to location where septage truck will park;
- Step 4:** Estimate elevation gain or loss between septic tank and parking location;
- Step 5:** Identify truck access issues: flooding, width of roads, weight restrictions on roads; and
- Step 6:** Explain the planned septage management program to the owner.



*Septic Tank Safety: Never enter a septic tank and never smoke around a septic tank because of the toxic and flammable gasses they contain. Wash your hands with soap after coming in contact with a septic tank, and ensure that the access ports are securely closed so that children can't open them.*



How often should we desludge?

The optimal desludging frequency is based on a number of factors, including the average number of people in the household, average volume of the septic tank, diet, physical structure of the septic tank, and if greywater is or is not treated along with the blackwater in the tank. In the Philippines, a good starting point is 5 years. If after the first cycle more than 20% of the homes require intermediate desludging (before the next 5 year cycle) consider reducing the desludging frequency to 4 or even 3 years.

Not all septic tanks will be accessible for desludging. To be accessible, the tank should be within 25 meters of where the truck would park and not more than 4 meters down slope of the parking area, and have an access port that can be opened and closed (if the tank is incorrectly located under a house or building a hole has to be cut through the floor; some people may not be willing to do this). More information on RTAs can be found in Annex A of the National Sewerage and Septage Management Program, which is available from DPWH.

To make a rough estimate of the daily flow, you need to estimate the number of septic tanks that are accessible for desludging and the average volume of the septic tanks, based on the information collected during the RTA. If you will desludge each tank once every 3 years and do collections 5 days a week, you can use the following formula to calculate the number of cubic meters of septage to be collected and treated per day.

$$\begin{array}{l}
 \text{No. of septic tanks} \times \text{Average volume of tanks} \div 3 \text{ years} \div 5 \text{ working days/year} \\
 = \text{Volume of septage to be treated each day (daily flow)}
 \end{array}$$



Now that you know the daily flow, you can figure out the size of the major components in a lime stabilization system. You also need to choose between a lagoon or constructed wetland for the secondary treatment portion of the system. Then you will have a better idea of how much land you need and the cost of construction. The decision to use a constructed wetland or lagoon is based on availability of gravel for the wetland, space available, and depth to seasonally high groundwater. If gravel is readily available and depth to seasonally high groundwater is high (less than 2 meters below grade), a constructed wetlands would be better than a lagoon. If groundwater is lower than 2 meters, and gravel is limited or expensive, and there is enough space, go with the lagoon. If space is limited or groundwater too high, other technologies should be explored. Use this guidance for getting “ball park” or rough estimated figures for planning purposes only.

Lime stabilization systems should be designed by skilled engineers. When possible, seek assistance from the city or municipal engineering office or even outside consultants if more complex systems are proposed. Or, request technical assistance from your local DPWH office. And don't forget to get the required permits from local and national government agencies (see the section on regulations on page 69).

## Sizing of Key Components

### Sizing Sand Drying Beds

Sand drying beds are a bit difficult to size because the dimensions depend on the total amount of dry solids in the septage you are collecting. This can vary greatly from 3% to typically not more than 20%, and you won't really know until after you have processed a number of loads of septage.

Some things to *remember* about your sand drying beds:



- They should be constructed in cells;
- Each cell should be controlled by a single valve for loading the cell;
- The dimensions of the cell should be big enough to handle a batch of septage from the reactor tank, but not so big that workers cannot reach the septage from the sides with long-handle rakes; and
- You should have 0.3 meters of washed sand over 0.4 meters of gravel (to support the underdrain system), with supporting walls constructed of concrete block.





Say you run your system by treating 4 truckloads of septage in one batch per day, 5 days a week at your facility. Each truckload is 2 cubic meters, so that is 8 cubic meters to process every working day. How big should your sand drying bed be??

First, consider that 100% of the stabilized septage will flow to the sand drying beds. About 70% of the volume will be liquid that will flow through the sand drying bed to the underdrain within a few hours. The remaining 30% is composed of solids and more tightly bound water. You will need to dry that in a 20 centimeter layer for 6 days. Here is the math:

- Daily flow / septage volume = **8 m<sup>3</sup>**
- Estimate % (by volume) of sludge that will remain after liquid initially drains off = **30%**
- **V** = Volume of sludge that remains after liquid drains off: 8 m<sup>3</sup> x 30% = 2.4 m<sup>3</sup>
- **h** = Height of sludge in the cell (0.2 m)
- **V/h** = volume of sludge that remains after liquid drains off
- **2.4 m<sup>3</sup> / 0.2 m = 12 m<sup>2</sup> of sand area.**

$$\frac{V}{h} = \text{size of sand beds}$$

Remember, the formula above only calculates the size of sand beds for each day of operation per week. So multiply by 5 for the number of working days per week for the total area of sand drying bed required. In this case it is 12 m<sup>2</sup> x 5 days = 60 m<sup>2</sup> of sand. That is a pretty big space!

#### To build your sand drying bed, follow these steps:



1. Install the walls around the sand filter cell, usually with concrete block.
2. Install a plastic liner. Use thick plastic sheeting with waterproof seams.
3. Install a 10 to 16 centimeter perforated pipe on top of the plastic. The holes should be 0.5 centimeters in diameter drilled every 30 centimeters on both sides of the pipe where it is under the filter. This underdrain pipe will collect the effluent and pipe it to the next step in the treatment process. It should be sloped at a 2% grade.
4. Fill in the bed with gravel so that it covers the pipe by about 15 centimeters.
5. Add the sand. Between 30 and 50 centimeters of sand depth is recommended.



## Sizing ABRs

You should generally size your ABR to achieve 2.5 to 3 days detention time, but check with your design engineer to get the exact specifications for your facility. We are assuming the effluent from the sand drying bed underdrains will have a BOD of approximately 500 milligrams/liter. About 2.5 to 3 days detention time should be adequate to bring the BOD down to a level suitable for the secondary treatment stage.

Detention time = volume / days,

SO

**volume (of ABR) = daily flow x detention time**

Use this formula for sizing the ABR:

**ABR size = daily flow x 60% x detention time**

In our experience, ABRs should be 3 times longer than they are wide, have a minimum liquid depth of 1.5 meters, and have a minimum of 3 baffles separating the compartments.

The next step in the process is secondary treatment. You may choose either lagoons or constructed wetlands. A disinfection pond will be needed following either one.

## Sizing Lagoons and Disinfection Ponds

If you have enough space, you can install sewage lagoons for secondary treatment.

- For treatment lagoons, use the services of an experienced engineer, or contact DPWH for technical advice.
- For disinfection ponds, size at 1 meter deep and a detention time of 3 days.



*Remember that the effluent collected in the underdrain will flow to the ABR. The volume is less than the volume of septage delivered to the facility, as much of the solids are left behind on the sand drying beds, and some of the water is lost to evaporation. 60% of the incoming septage is a reasonable estimate of the volume of effluent that will flow to the ABR and downstream equipment.*

# Sizing of Constructed Wetlands

Constructed wetlands are typically sized to achieve 3 to 5 days detention time. Actual detention time will be determined mostly by the strength of the septage and climate, as well as how much empty space is in the gravel.



*When installing constructed wetlands, it is often easiest to locate natural wetlands nearby where plants may be harvested. If you will use this method, don't take more than 25% of the plants from the natural wetlands, and use care when removing them to minimize damage to the natural site while maximizing the survival rate of the harvested plants. Avoid using nursery stock and don't use exotic species that have the potential to become invasive.*

Subsurface flow constructed wetlands are typically designed based on a 1:3 aspect ratio, with gravel depth no more than 1 meter. Use native wetlands plants, like tambo (reed), or native willows or other wetland species. For surface flow wetlands, use floating aquatic plants like water hyacinth, water lily, or duckweed, but be aware that you will need to cut them back if they start covering the entire surface of the water.

Let's take the example of 1 cubic meter of gravel that we will place in a box that is 1 meter long by 1 meter wide by 1 meter deep. Now, let's add water just to the point that it overflows. This water filled up the empty space. Now, how much water did you add? If you added 300 liters of water, your gravel has 30% empty space.

Now, we want to find the area needed for the wetland. We know that the depth of gravel is 1 meter, and we know the volume of septage. For this example, let's say it is 10 cubic meters per day. And from the experiment above, we know that this sample of gravel has 30% empty space. We know that the detention time can range from 3 days for low-strength septage to 5 days for high-strength septage.

Here is the formula:

$$\text{Area} = \text{depth} \times \text{septage volume} \div \text{x detention time (days)} \div \% \text{ empty space in the gravel}$$

*At 3 days detention time:*

$$1 \text{ m} \times 10 \text{ m}^3 \text{ per day} \times 3 \text{ days} \div 0.30 = 100 \text{ m}^2$$

*At 5 days detention time:*

$$1 \text{ m} \times 10 \text{ m}^3 \text{ per day} \times 5 \text{ days} \div 0.30 = 167 \text{ m}^2$$

So the wetlands will range in area between 100 – 167 square meters depending upon the strength of the septage.



# Guarding Against Climate Change Impacts

Typhoons, storms, floods and droughts are becoming more extreme each year as climate change impacts intensify. That's why you should consider climate-proofing the design of your lime stabilization operations to minimize damage and keep it functioning after disasters. Section 7 talks more about how to prepare for disasters and operate emergency lime stabilization systems.

In general, the following climate change impacts related to your facility can be expected:

1. Faster evaporation of water due to higher temperatures;
2. Flooding and damage from rain and coastal storm surges;
3. Loss of coastal areas (which affects facilities located close to the coastline);
4. Increased fire risk and altered vegetation due to changes in temperature and rainfall; and
5. Changes in energy needs and increase in costs.



You can guard against these impacts, as well as earthquakes and other disasters, by following the advice below when designing your lime stabilization and other septage treatment facilities.

- Protect systems from flood waters by installing berms around tanks, pits, ponds and wetlands, and elevating manholes, access ports, and electrical boxes and control panels 0.5 meters above the maximum anticipated flood elevation;
- Pipelines, tanks and access ports should be sealed with watertight fittings and tested for leaks prior to being used, with manhole lids elevated above the maximum anticipated flood level;
- Electrical connections should be in water tight and explosion-proof electrical boxes (including generators);
- Make sure that all buildings can withstand very strong winds and excessive rainfall. Refer to the Philippine Atmospheric, Geophysical and Astronomical Services Administration's climate projections for your area to find out if you are expected to have more or less rain in the future and projected wind velocity during storms; and
- Identify the roads that will be used for transporting septage from communities to the treatment facility during flooding conditions.



For more information, see the EPA's *Adaptation Strategies Guide for Water Utilities, 2012*.  
<http://water.epa.gov/infrastructure/watersecurity/climate/upload/epa817k11003.pdf>

At the community level, promote programs for proper design and construction provisions for latrines, septic tanks and on-site wastewater management systems to protect against wash-out in flood prone areas and develop procedures for desludging, inspecting and repairing existing septic tanks and latrines after flooding events.

# Worksheet

## I. Determining Your Volume

### a. Conduct a Rapid Technical Assessment

Estimated number of septic tanks in your area: \_\_\_\_\_  
 Estimated percentage that are accessible for desludging: \_\_\_\_\_  
 Estimated total number of desludgable septic tanks: \_\_\_\_\_  
 Estimated average volume of septic tanks: \_\_\_\_\_

### b. Calculate Design Flow

Fill in the following:

$$\frac{\text{_____}}{\text{number of septic tanks}} \times \frac{\text{_____}}{\text{ave. volume of tanks}} \div \frac{\text{_____}}{\text{number of years}} \div 260 \text{ working days per year} =$$

\_\_\_\_\_

*volume of septage to be treated each day (design flow)*

## 2. Sizing of Key Components

### a. Sizing Sand Drying Beds

$$\frac{\text{_____}}{\text{daily flow}} \times 30\% \div \text{height of sludge in cell} = \frac{\text{_____}}{\text{size of sand drying beds}}$$

### b. Sizing ABRs

$$\frac{\text{_____}}{\text{daily flow}} \times 60\% \frac{\text{_____}}{\text{detention time}} = \frac{\text{_____}}{\text{size of ABR}}$$

### c. Secondary Treatment

Choose lagoons or constructed wetlands: \_\_\_\_\_

Sizing Constructed Wetlands

$$\frac{\text{_____}}{\text{depth}} \times \frac{\text{_____}}{\text{effluent volume}} \times \frac{\text{_____}}{\text{detention time (days)}} \div \frac{\text{_____}}{\% \text{ empty space in the gravel}} = \frac{\text{_____}}{\text{area}}$$

## 3. Guarding Against Climate Change Impacts

### Checklist for Design

Action	Incorporated in Design? (Yes or No)
Install berms around tanks, pits, ponds and wetlands. Elevate electrical boxes and control panels, manholes and access ports.	
Elevate and include 0.5 meters above the maximum anticipated flood elevation.	
Seal pipelines, tanks and access ports with watertight fittings and tested for leaks prior to being used.	
Electrical connections are in water-tight and explosion-proof electrical boxes.	
Buildings follow the new design standards set by DPWH.	
Identify the roads that will be used for transporting septage from communities to the treatment facility during flooding conditions.	





# Choosing your Site

# 5

Implementer's Guide to  
Slime Stabilization for  
Septage Management  
in the Philippines









# Choosing Your Site

## How Much Land do I Need?

Now that you know the daily flow and the size of the key components, you can begin to make some rough estimates on the size of the land you will need. Take a look at the sample facility layout below for the planned 15 cubic meter per day lime stabilization system in Tacloban City. Its dimensions are roughly 40 meters by 20 meters, or 800 square meters. The existing building shown in Figure 18 (page 44) is the location for the proposed reactor tanks. If these are elevated, then the septage will be able to flow by gravity from one component to the next and pumps will not be needed (see Figure 4, page 20). For planning purposes, use this simple guide on the size of land for your facility:

Daily Flow	Parcel size required
5 cubic meters per day	400 square meters
10 cubic meters per day	600 square meters
15 cubic meters per day	800 square meters
20 cubic meters per day	1000 square meters

These land sizes allow for movement of people, carts for sludge handling, and perhaps even vehicular traffic between system components, which helps to simplify the operation and maintenance activities. It also allows for some biosolid storage, storage of lime and other supplies, distance from neighbors, and an administration building.

## Finding a Suitable Piece of Land

Try to find a suitable piece of land that is:

- Not at high risk for geohazards such as landslides, flooding, volcanoes or earthquakes;
- Not within an environmentally critical area as defined by DENR;
- Has a slight incline to allow for gravity flow;
- Accessible to the expected truck traffic;
- Not too close to residential housing areas; and
- Near creeks or public drainage systems where treated effluent can be discharged.

To assess geohazard risk, look at the geohazard maps prepared by the Mines and Geosciences Bureau of DENR to make sure that the site is not at high risk. The maps are available at <http://www.mgb.gov.ph>. If an area is highly vulnerable to geohazards, a risk assessment should be conducted. (See page 39 for climate change impacts that you should consider when choosing a site.)



# Parcel Suitability Checklist

Once proven not to be within a high geohazard risk area or environmentally critical area, use this checklist to verify a parcel's suitability, or to rank multiple parcels of land.

Parameter	✓
The parcel is large enough to accommodate the estimated size of the treatment facility.	
There is enough room for trucks to turn around.	
There is enough space in between units for movement of hand carts or pickup trucks.	
The parcel is close enough to residential housing so that truck delivery is affordable.	
The parcel is not too close to residential housing as to cause complaints.	
The parcel is not in a flood zone.	
The parcel is in an area that is zoned for industrial or agricultural use.	
The parcel is not in a critical watershed or within 100 m of a drinking water intake.	
Access is not limited due to truck weight, road size or seasonal flooding.	

Figure 18. Layout for the planned lime stabilization system in Tacloban City.

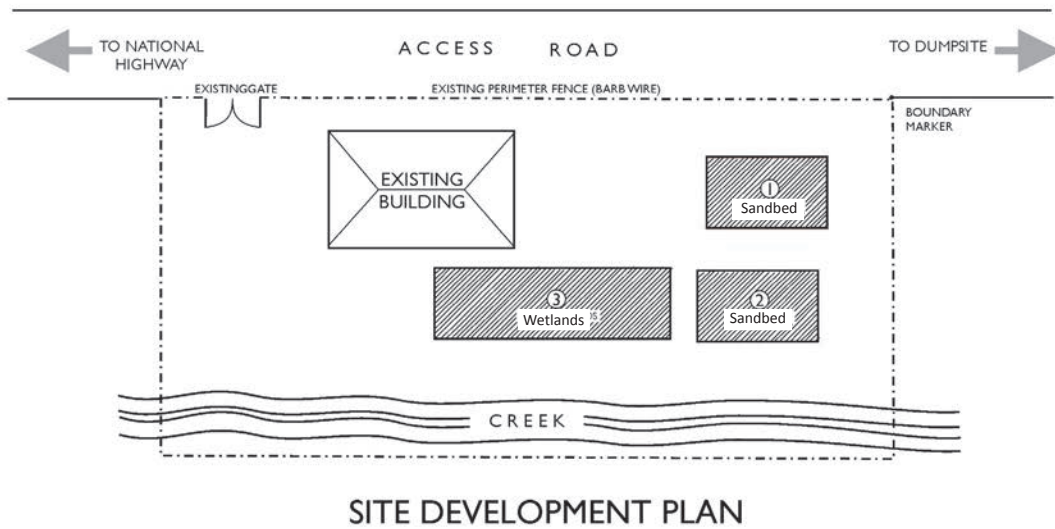

**Question:** Do you notice something strange about the plan above?

**Answer:** *There is no place for the truck to turn around. Make a number of drawings with different configurations until you have one that will work best. Be sure to include topography, water features, utility lines and setbacks.*



# Develop a Site Plan Sketch

A site plan sketch will be useful to you throughout your project.

- DPWH will utilize it for review of your project for technical assistance and possible counterpart funding;
- Department of Health will utilize it for their evaluation and issuance of the Environmental Sanitation Clearance;
- DENR will utilize it for review and issuance of the discharge permit you will apply for; and
- You will use it to communicate information about your project to the mayor, council, and other stakeholders.



*Think about where trucks and other vehicles will park when selecting a site for your septage management facility.*

The site plan sketch will help you decide how much land you need. When drawing the site plan sketch, consider:

- Location of treatment components;
- Movement of workers and vehicles around the treatment equipment;
- Storage area for treated biosolids; and
- Space for future expansion.



*Ask the LGU planning office to draw the site plan and check the land use and zoning of surrounding land. The engineering office can help verify access, road conditions, weight restrictions and other constraints.*

Your site plan sketch should also include property lines, wells, buildings, slope and topographical information, floodplains and drainage systems, and soil testing locations. It should show the access and parking areas for delivery trucks and be drawn to scale.

The site plan drawing (Figure 19) begins with a plan view of the site and key features of the development. Once you prepare this, additional features of the site plan, including topography, high groundwater and surface water can be added.

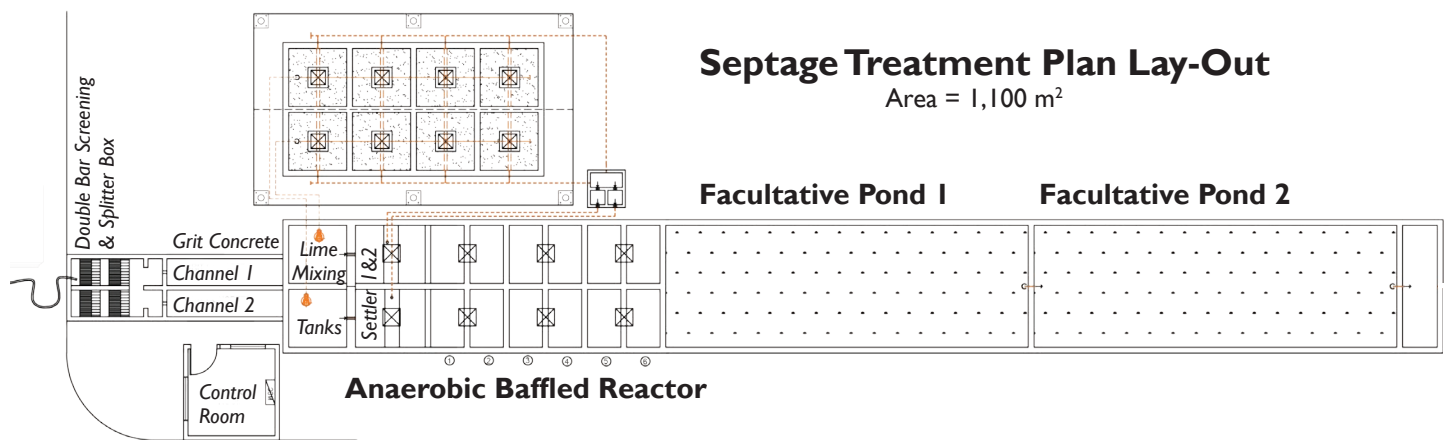

Figure 19. Initial site plan drawing for a hypothetical septage treatment facility.

# Worksheet

## 1. How Much Land do I Need?

Rough estimate of parcel size based on your projected design flow:

## 2. Finding a Suitable Piece of Land

Ranking your potential sites (1=no, 2=yes)

Parameter	Score for Site 1	Score for Site 2	Score for Site 3
Not at high risk for geohazards			
Not within an environmentally critical area			
Has a slight incline to allow for gravity flow			
Accessible to the expected truck traffic			
Not too close to residential housing areas but not too far away to make trucking too expensive			
Large enough to accommodate the facility			
In an area that is zoned for industrial or agricultural use			
<b>Total Score</b>			

## 3. Develop a Site Plan Sketch

Place your sketch here:





# Operations and Maintenance

# 6

Implementer's Guide to  
Lime Stabilization for  
Septage Management  
in the Philippines









# Operations and Maintenance

Operations and maintenance (O&M) is a critical component of any septage management system. In this section we present the general operations requirements for lime stabilization systems. But first, let's review the important components of a good O&M program.

## Components of a Good O&M Program

Your O&M program should have the following components:

Components of a Good O&M Program	✓
Written O&M plan	
Written job descriptions and personnel policies	
Written health and safety plan	
Site safety and security plan	
Worker training program – health and safety and process control and monitoring	
Operator's log book	



*The operator is responsible for worker health and safety in every area of the treatment facility. The workers themselves have a responsibility too. The operator enforces compliance with PPE requirements, and monitors activities of non-staff (such as contractual truck drivers) while they are on site.*

# Operating your Lime Stabilization Facility

This section describes, from the operators' perspective, the full lime stabilization septage treatment process, from the time the load enters the facility, to the time the septage is processed and dispersed.



## Step 1: Truck arrives at the yard for unloading

The truck driver should ensure the safe transfer of the septage from the truck to the facility by doing the following:

- Block the truck wheels.
- Give the operator the manifest form, which includes the origin of the septage and whether it is from a residential or commercial source.
- Provide a sample of the septage to the operator if requested.



*Traffic control during busy times at the facility is critical. Drivers must follow all instructions from facility personnel. Coordinate training of operations staff with drivers when possible to improve on-site coordination.*

The operator should spot check the septage for

- Odor – note any odor of hydrocarbons or other chemicals;
- Color – black or dark brown is normal – other colors are suspect; and
- Presence of grease or oil.



*The operator is responsible for checking loads that come into the facility. Non standard loads, such as those contaminated by fuel or other contaminants, should be segregated and treated separately using the lime stabilization process.*



## Step 2: Connecting the discharge pipe from truck to receiving port

- The driver should make the connections using quick couplers (Figure 20) if available between the truck tank and the receiving port for the facility.
- The driver waits for the operator to signal it is okay to start pumping. Only at that time should the pump be engaged to begin transferring waste from the truck to the facility.



Figure 20. Quick couplers make for water tight fittings and allow rapid connections.



Most of the tasks described below can be accomplished by workers with minimal training. The operator is ultimately responsible and should review all work.



Workers must be responsible for wearing eye protection (goggles) and other PPE, especially when mixing lime to form the slurry.

## Step 3: Pre-treatment

Septage should be screened using trash screens before reaction, to remove any rags or other non-biodegradable solids (which should be put in a landfill). Such debris will make the treated septage unsellable as a soil amendment, and could damage treatment equipment. After screening, the waste should then flow to a grit chamber to remove any sand and gravel in the waste. Some smaller facilities may not have this equipment. In such cases, the waste flows directly to the reactor pit.

## Step 4: Filling the reaction tank

- When the septage is flowing to the reactor tank or pit, the operator should look for proper color and be aware of any off odor from hydrocarbons or other chemicals. If present, that load will have to be segregated for treatment and drying away from the domestic septage. If it is contaminated with fuel oil, it cannot be applied to land after treatment.
- Monitor the filling process. Be prepared to shut it down in case of a broken pipe or separated coupling.



Figure 21. Observe the color of the discharge. Black or very dark brown or grey is normal. Any other color could indicate industrial pollutants.



**PREVENT BLINDNESS.**  
Wear eye protection every time you or your staff handle hydrated lime.

**AVOID** wearing contact lenses when working with hydrated lime.

## Step 5: Adding the lime

Use only hydrated lime for septage or wastewater stabilization. The amount of lime needed depends on the quality of the lime, how well it is mixed, and the temperature. Start with 20 kilograms for 4,000 liters of septage using the following procedure. Use a batch system – once you start adding lime and mixing don't add any more septage.

- Make the slurry by mixing 20 kilograms of lime into 60 liters of water. Put 10 liters of water into a 20 liter bucket and start mixing in the lime 1 kilogram at a time – about 3.3 kilograms per bucket. Never put the lime in first and then add water – that is a recipe for disaster! Always put the water in first and slowly add lime to avoid preventable violent reactions.
- Once each bucket of slurry is prepared, pour the slurry into the 4,000 liters septage and mix. Repeat five more times for a total of six buckets (60 liters of water).



## Step 6: Mixing and testing pH

- Once all six buckets of slurry have been added, keep mixing and start checking the pH every 5 minutes using a standard hand-held pH meter. Get a sample with a dipper and place it in a bucket, which is safer than dipping the pH meter directly into the pit. If after 15 minutes of mixing, the pH doesn't reach 12, mix in more lime slurry. Keep track of how much lime goes in so you will know how much to use for the next batch.
- Once pH of 12 is reached, continue to mix for 30 minutes.
- A mechanical mixer using either a pump, paddle, or air blower connected to coarse bubble diffusers placed at the bottom of the pit is ideal.
- If a mechanical mixer is not available, manually use a wooden paddle specially designed for your pit so that all of the sludge (even that which settles to the bottom) gets mixed.
- It may be difficult to get the pH to 12 using manual mixing. If you can only reach pH 11 you will need 24 hours of contact time before putting the septage in the sand beds.



Figure 22. Hand mixing is inefficient and labor intensive. Mechanical mixing with paddles, blowers or pumps is better.

## Step 7: Settling

Once you have met your pH and time requirements, turn off the mixers and allow the waste to settle. Heavier solids will settle rapidly, but it will take longer for the lighter suspended solids to settle to the bottom. Thirty



Figure 23. Checking the pH with a hand-held pH meter.

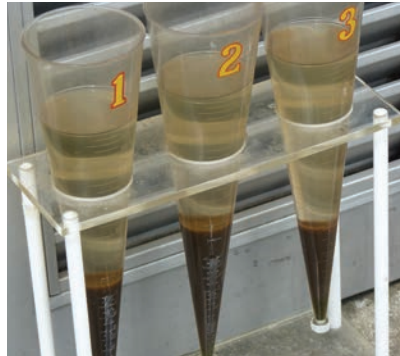

Figure 24. Imhoff cones. Perform sludge settleability tests with this inexpensive device.



View the instructional video on how to use a hand-held pH meter from this link: <https://youtu.be/YwfWR2woWI4>

minutes is the minimal acceptable settling time. If you are able too, let it sit overnight. The reaction will continue for up to 22 hours. An Imhoff cone settler can be used to determine how much settling time is needed.

## **Step 8: Transfer to the sand drying beds**

If possible, set your facility up so that everything drains from the reactor tank and through the rest of the system by gravity. If this is the case, use the following procedure:

- Immediately after the mixing and settling, open the gate valve from the reactor tank.
- The now stabilized septage will flow by gravity through a junction box and to the sand bed. The junction box will allow the operator to choose which sand drying bed to send the batch to.
- Fill up the bed with septage in a layer that is 20 centimeters thick, wait two to three hours for the free water to drain through the sand, fill up to 20 centimeters again.
- Let the septage sit on the drying beds for 6 days or so, until it reaches 25% solids.

## **Step 9: Removing dried biosolids from the drying area**

- Remove the biosolids from the drying beds manually using long handle rakes and shovels and transfer to a covered storage area.
- If the stabilization process was done correctly, the biosolids can now be spread onto agricultural land. If you are not sure, you can leave the biosolids on the drying beds for 16 days or compost or stockpile them until the moisture content is less than 5% (which can be measured by a laboratory). If you stockpile, make sure the site is protected from rain.

**LIME-TREATED BIOSOLIDS ARE SAFE AND PROMOTE RECYCLING:** As EPA notes, “properly prepared biosolids provide a rich source of the essential fertilizer elements needed by the plants to produce food. It seems only natural to return this rich source of nutrients and organic matter back to the soil to perpetuate the cycle of life... Hundreds of studies have been conducted as a basis for the safe use of biosolids. Moreover, thousands of publicly owned treatment works (POTWs) are currently using their biosolids as an organic fertilizer and solid conditioner...” Simply put, “years of research and practice have repeatedly demonstrated that biosolids recycling is safe.”

*Source: National Lime Association. Fact Sheet on Using Lime to Stabilize Biosolids, 1999.*



## Step 10: Secondary treatment

- Effluent from the pipes under the sand drying beds flows to the ABR and then to either the lagoon or constructed wetland.
- Effluent coming from the lagoon or constructed wetland flows to the disinfection pond or chlorinator and contact chamber.
- After disinfection, the water can be released into the environment in compliance with DENR standards.

For systems where gravity feed is impossible, the flow pattern is the same, but lifting the septage (by pump preferably) will be required. There are 3 options:

1. **React – settle – decant.** After reacting the septage with lime, wait overnight for the solids to settle. Then pump the liquid out until you get close to the solids layer (you may need a generator to power the pump). Transfer the liquid to the sand beds for removal of fine suspended solids. Then use a vacuum or pumper truck to pump the solids directly to the sand beds. This becomes more efficient if there are multiple pits that can be emptied at the same time.
2. **React – pump.** Use a solids handling pump and larger generator to pump your stabilized septage directly to the sand drying beds after the stabilization process is concluded. Mix again briefly to place the solids in suspension, and then pump the mixture to the sand beds.
3. **Manual handling.** This should only be used as a last resort. No one should ever enter the reactor tank and PPE use and good hygienic practices are mandatory.



# Health and Safety

Here is an overview of health and safety issues you need to know to ensure that your workers are properly informed and protected. In addition, never enter tanks or enclosed spaces without using proper breathing equipment. People die every year from entering tanks, so extreme caution is required.

## Eye Protection



Anyone handling and mixing hydrated lime must wear safety goggles. Safety glasses or a face shield will not protect you enough from the very fine dust particles or splashing of lime solution, which can be painful and in some cases cause permanent eye damage or blindness. If lime gets in your eyes, flush with clean water for at least five minutes.

## Dress Appropriately for the Job

The clothes you wear will help protect you from many hazards on the job. Long-sleeved shirts, boots and a hard hat can reduce and/or prevent injuries such as cuts and skin irritation. Wear light weight, loose fitting long sleeve shirts when working with hydrated lime. Or consider wearing an apron made of resistant materials.

- Work gloves can help protect your hands from irritation common with working with hydrated lime and sludge material in general. Latex, rubber, and even canvass gloves can help protect your skin.
- Keep gloves and clothing clean, and don't wear work clothes home. They may become contaminated from fecal sludge, which can transmit pathogens to your family.
- Always wear your hard hat – they may be uncomfortable and hot, but they can save your life.
- Adjust hard hats so that they are comfortable, and sit slightly above your head to absorb any impact.





## Footwear

Septage treatment facilities are considered industrial locations and appropriate footwear will help prevent injury. Often uneven ground is a hazard for sprains, and debris from construction materials can also cause injury.

- Wear hard-soled shoes such as boots to help prevent puncture injuries.
- Wear work shoes with a higher top/ankle support to help prevent sprains.
- Footwear should provide you with adequate arch support to help reduce fatigue.
- Footwear must cover the foot - sandals and flip flops are not allowed.



## Maintaining your Lime Stabilization Facility

All wastewater facilities require ongoing maintenance and lime stabilization systems are no different. Operators should keep a maintenance log book and record all activities. The following are recommendations for your maintenance program:

1. Identify the equipment and other parts of your system that will require | periodic maintenance. These may include:
  - a. Pumps and mechanical equipment;
  - b. Concrete that may deteriorate due to the high pH created by the lime stabilization process;
  - c. Painted surfaces that will need repainting after a few years;
  - d. Sand drying beds that may require addition of sand from time to time;
  - e. Wetland cells that may require weeding or plant thinning;
  - f. Berms that may deteriorate over time due to erosion or animals digging;
  - g. Trash racks and grit chambers that will need cleaning; and
  - h. Other components that may be unique to your facility that may require maintenance.
2. Develop a regular inspection program to visually inspect each of these critical locations throughout your facility at least once a month. Make sure to document the inspection.



*Keep lime in a dry location and away from other chemicals, such as strong acids or bases. Storing lime in bags over long periods of time (more than one year) may result in caking or solidification of the lime.*

3. Conduct regular training activities so everyone knows their role.
4. Keep a file of all manufacturer's product literature and maintenance requirements and follow the procedures exactly.
5. Determine what spare parts will be needed, buy them in advance and keep them in a locked storage area.
6. Develop a schedule for preventative and regular maintenance and follow it.
7. Repairs on plumbing and electrical components should be conducted by qualified service providers. For maintenance on electrical components, make sure that circuit breakers are turned off and remain off during the maintenance or repair procedure. You can use the "Lockout / Tagout" procedure as developed by the Occupational Safety and Health Administration in the US. Follow this link for details:  
[https://www.osha.gov/OshDoc/data\\_General\\_Facts/factsheet-lockout-tagout.pdf](https://www.osha.gov/OshDoc/data_General_Facts/factsheet-lockout-tagout.pdf)
8. Never enter tanks or enclosed spaces without checking the air quality or using proper breathing equipment. People die every year from entering tanks, so extreme caution is required. Always use the buddy system where the person entering the tank has a harness connected to a safety rope. The buddy always remains outside of the confined space. Review the procedure at this link: <https://www.osha.gov/SLTC/confinedspaces/index.html>

Proper maintenance will help to ensure the sustainability of your facility and minimize down time due to broken equipment.





# Short-Term Planning for Disasters

## 7

Implementer's Guide to  
Lime Stabilization for  
Septage Management  
in the Philippines









# Short-Term Planning for Disasters

While preparing for your permanent lime stabilization facility, you should review the following guidance and make a plan on how you will manage fecal sludge (from raw sewage collected from portable toilets) and septage in case of a disaster. During and following natural or man-made disasters, power and water may be out, community services stop, but people still continue to defecate. Once the storm subsides, septic tanks are often inundated by storm water, and public and evacuation center toilets are so overused they become non-functional. Aid agencies often bring portable water treatment systems and portable toilets, and sometimes even vacuum trucks to collect waste from evacuation centers. It is important for this waste to be properly treated to prevent diseases and pollution of the environment.

## Septage and Wastewater Management during Disasters

Before a disaster hits, you should have the following in place:

- Enough portable toilets to service likely affected communities;
- Enough pumping trucks to empty the portable toilets and those at evacuation centers;
- A program for rehabilitating (or abandoning and replacing) flood damaged septic tanks. Often, these structures become so clogged with silt, that it is better to replace them (and it's an opportunity to put in septic tanks that have the correct design required by law);
- A piece of land that is high and dry, and capable of serving as a temporary treatment facility, as well as a plan for treating the septage following the guidance below;
- A locked storage shed that will remain dry during storm conditions and contains 100 bags of hydrated lime (calcium hydroxide), mixing paddles and PPE such as work gloves; and
- Fuel for trucks as this is often hard to get after a disaster.



*Make sure that the portable toilets, pumping trucks and fuel are located in low-risk areas and protected from disaster impacts such as flooding.*

The following checklist contains the main things you need to be prepared for a disaster:

Parameter	✓
Site is level and not prone to flooding	
Soils are at least 1 meter deep before encountering groundwater or bedrock	
Site is accessible by tanker trucks, and away from water sources	
Site is large enough to accommodate the volume of sludge to be collected	
Storage facility for hydrated lime is dry, locked and protected from floods	
Storage shed contains mixing paddles, shovels and PPE	
Trained personnel are available and on call for service during disasters and emergencies	

The process for lime stabilization following a disaster focuses on reaction in trenches or pits, with liquid effluent being discharged to the environment, or first put on sand drying beds.

In Tacloban City, the emergency lime stabilization facility established following Super Typhoon Yolanda used the following process: operators reacted the septage in lined pits and let it sit in the pits for a day to allow the solids to settle to the bottom. Then they pumped the liquid effluent out and disposed of it on land. Then the solids were manually removed using buckets and carts. This is not an ideal solution, but workable in a post-disaster situation. The city is now developing a more permanent gravity-fed system.

Figure 25. Trench system for lime stabilization of septage in disasters.



## Lime Stabilization in Trenches – A One-Step Process

Mixing hydrated lime with the raw wastewater or fecal sludge in trenches (Figure 25) is one simple and low cost alternative.

In all but the most tightly packed clayey soils, effluent will soak away leaving the solids behind. When covered with the native soils, organic matter left over from the septage will decay and become part of the soil.

In emergencies this is a relatively easy and safe procedure. And it is not a bad solution, as long as there are no potable water intakes or wells nearby.



However, it is important for you to check the soils first to make sure they can absorb the liquid. If they contain too much clay or if the groundwater is too high, the site might not be suitable. Dig test holes with a shovel to a depth of about 1 meter. Take a sample of soil in the palm of your hand, mix it with water until pliable, and if you can make a ribbon longer than 2 centimeters, it has too much clay. If you find groundwater in the test holes, the site is also not suitable.



*It is best to use an excavator, but if not available you will need to dig the trenches by hand. Have enough shovels and work gloves for a crew of 15 to 20 workers.*

## Two-Step Process using a Reactor Pit and Sand Drying Beds

An improvement over the trench design is the use of a mixing pit and drying beds to provide treatment. You can also use this two-step process if there is not enough land area for the trench system, or groundwater or bedrock is less than 1 meter from the surface. Install a lined reactor pit (Figure 26) where each truckload of septage can be reacted with the hydrated lime and then transferred to sand drying beds.



*Figure 26. This is a reactor pit in Palo, Leyte, which was first built after Super Typhoon Yolanda. Here, workers stabilize the septage with lime, then transfer it to sand drying beds.*

Parameter	✓
Pits are at least 1 meter deep by 2 meters square – 4 cubic meters is a good sized batch	
In all but clay soil, pits are lined with plastic	
Generator is standing by (if possible) with effluent pumping system	



*Transferring treated septage from the lime pit to the drying bed can be tricky if you do not have a gravity flow system. One option is to use a sludge pump. Another option is to utilize the desludging truck that can pump or vacuum out the contents of the pit, and transfer it directly to the drying beds. Avoid the use of manual emptying (bucket brigades) if at all possible.*



*Lime stabilized septage should be considered “infectious material” and should not come in contact with exposed skin. All workers must wear PPE.*

# Step-by-Step Process for Emergency Lime Stabilization Systems



1. **Locate the site.** It should be well away from water sources and on level ground that is not saturated with water.
2. **Determine if the site** is suitable for trench system. If so, dig the trench one meter deep by one meter wide and long enough for the anticipated flow. Each one linear meter of trench will accommodate between 0.25 – 2 cubic meters per day of flow, depending upon the soils (see #3 below).
3. **Determine application rate.** Refer to the chart below for the amount of septage based on soil type. See (insert website) for help in determining your soil type, or contract with a soils lab. There are many in the Philippines.

Follow this guidance for the amount of septage that can be treated per linear meter of trench:

Soil Type	Trench Length	Amount of Septage
Sands and gravels	1 linear meter of trench	2 cubic meters/day
Loam, sandy loam, silt loam	1 linear meter of trench	0.75 cubic meters/day
Clays	1 linear meter of trench	0.25 cubic meters/day

During emergencies, it might be possible to contain all of the effluent and biosolids on site in the trenches and not remove and treat the effluent and biosolids. While this is okay for emergencies, it is not okay for regular operations.



In emergency or disaster settings, it is okay to mix each successive load of septage with lime slurry as the truck discharges the septage to the ditch. In permanent lime stabilization systems, each batch is processed separately. The batch is reacted, stabilized, and transferred to the sand drying bed without new septage being added. You can have multiple loads per batch, but don't contaminate a lime stabilized batch with fresh septage.

4. After 3 days, **cover by filling in the trench** with soil from the initial excavation. Avoid overflowing.
5. **Dig a new ditch** and start again. In very clayey soils, the liquid will not seep into the ground and could run off the site. This could be a significant problem for downstream communities that rely on surface waters for domestic purposes. In this case, treat each batch with hydrated lime to





Figure 27. Worker levels stabilized sludge in a makeshift drying bed in an effort to keep biosolids on site in Tacloban City.

reduce the pathogens as much as possible. Try to contain as much of the effluent as possible on site once the treatment process is concluded. Use onsite drying beds (Figure 27) as one means of containing effluent and biosolids on site, or revert to the two-step approach as described above.

## Compliance During Disasters

For emergency facilities, compliance with rules on final disposal is often overlooked. However, worker safety is still of paramount importance. Septage workers are critical to the recovery effort after a disaster so their health and safety is important to maintain. Therefore, strict adherence to PPE usage and best practices for operations is required.



*While hydrated lime can be hazardous to health, it is not a hazard to the environment when used properly. After the initial reaction, pH of the stabilized septage will become neutral after a few days. Lime treated septage buried in trenches will add to the organic content of the soil and eventually decompose.*









# Regulatory Considerations

## 8

Implementer's Guide to  
Lime Stabilization for  
Septage Management  
in the Philippines



**USAID**  
FROM THE AMERICAN PEOPLE

Operations Manual on the Rules and  
Regulations Governing Domestic Sludge and  
Septage











# Regulatory Considerations

The following are some regulatory considerations for septage management programs.

## Department of Public Works and Highways

DPWH manages the National Sewerage and Septage Management Program (NSSMP). They offer technical assistance and possibly matching funds for projects. Access their program and application forms at: <http://www.dpwh.gov.ph/NSSMP/>. DPWH also has regulations on public safety during construction, such as fencing requirements, traffic management and restricting access.

## Department of Health

You must secure an Environmental Sanitation Clearance from the Center for Health Development of the Department of Health. This requirement applies to all new and existing septage management activities, expansion, or modification of permitted facilities.

## Department of Environment and Natural Resources

Likely you already know who your Environmental Management Bureau (EMB) representative is. Permanent septage management facilities may require discharge permits from DENR. Check with your EMB officer early on in the planning process. There may be permitting requirements for your facility before you may begin construction, such as an Environmental Compliance Certificate or certificate of non-coverage. Here is a link to the discharge permit application form: <http://emb.gov.ph/permitting/DischargePermitForm.pdf> If you are within the jurisdiction of the Laguna Lake development Authority, get the discharge permit from them.

## Local Ordinances on Septage Management

These are developed by the council and approved by the mayor. They set the procedures, rules and requirements for each aspect of the communities' septage management program including septic tank design and installation requirements, fees, desludging requirements, incentives, and penalties for non-compliance. Several LGUs have ordinances in place that can be used as samples.

# References

Chemical Lime Company. 2008. Material Safety Data Sheet: Hydrated Lime.  
<http://www.kernred.com/kern-agcomm/products/HYDRATED%20LIME.pdf>

Solomon, Clement, Peter Casey, Colleen Madkne and Andrew Lake. 1998.  
Fact Sheet: Septage Management. National Small Flows Clearing House.  
[http://www.nesc.wvu.edu/pdf/WW/publications/eti/Septage\\_tech.pdf](http://www.nesc.wvu.edu/pdf/WW/publications/eti/Septage_tech.pdf)

Strande, Linda, Mariska Ronteltap and Damir Brdjanovic, eds., 2014. Faecal Sludge Management: Systems Approach for Implementation and Operation. London: IWA Publishing.  
[http://www.sandec.ch/fsm\\_book](http://www.sandec.ch/fsm_book)

US EPA. 2014. Flood Resilience - A Basic Guide for Water and Wastewater Utilities.  
<http://water.epa.gov/infrastructure/watersecurity/emerplan/upload/epa817b14006.pdf>

US EPA. 2012. Adaptation Strategies Guide for Water Utilities.  
<http://water.epa.gov/infrastructure/watersecurity/climate/upload/epa817k11003.pdf>

US EPA. 1999. Decentralized Systems Technology Fact Sheet: Septage Treatment/ Disposal.  
<http://nepis.epa.gov/Exe/ZyPDF.cgi/200044F8.PDF?Dockey=200044F8.PDF>

US EPA. 1975. An Alternative Septage Treatment Method: Lime Stabilization/ Sand-Bed Dewatering.  
<http://nepis.epa.gov/Exe/ZyPDF.cgi/9100SNQA.PDF?Dockey=9100SNQA.PDF>

US EPA. Water Security.  
<http://water.epa.gov/infrastructure/watersecurity/>

Water Environment Partnership in Asia.  
<http://wepa-db.net/>

WHO/UNICEF. 2012. Joint Monitoring Programme for Water Supply and Sanitation 2012 Report.







**For more information, contact:**

**U.S. Agency for International Development  
Annex 2 Building, U.S. Embassy  
1201 Roxas Boulevard 1000, Ermita, Manila  
Website: <http://www.usaid.gov/philippines>  
FB: [facebook.com/besecureph](https://www.facebook.com/besecureph)**