

# Waste Flow Diagram

A rapid assessment for mapping waste flows and quantifying plastic leakage

## User Manual





## IMPRINT

### Published by:

Deutsche Gesellschaft für Internationale Zusammenarbeit (GIZ) GmbH  
Friedrich-Ebert-Allee 32 + 36  
53113 Bonn  
Germany  
Tel. +49 61 96 79-0  
Fax +49 61 96 79-11 15  
E-Mail: [Info@giz.de](mailto:Info@giz.de)  
[www.giz.de](http://www.giz.de)

The views and opinions expressed in this publication do not necessarily reflect the positions of participating authors, institutions or official policy positions of the governments involved during the application.



**UNIVERSITY OF LEEDS**

S. Blume  
Dag-Hammarskjöld Weg 1-5  
65760 Eschborn  
Germany

[Steffen.blume@giz](mailto:Steffen.blume@giz)

Dr. C. Velis and Dr. J. Cottom  
School of Civil Engineering  
University of Leeds  
Leeds  
LS2 9JT  
UK  
[c.velis@leeds.ac.uk](mailto:c.velis@leeds.ac.uk)



Dr. C. Zurbrügg and I. Zabaleta  
Eawag-Sandec  
Überlandstrasse 133  
8600 Dübendorf

J. Stretz  
Wasteaware Ltd.  
Wren House,  
68 London Road,  
St Albans, Herts,  
AL11NG  
UK

Published in September 2020

**Citation:**

GIZ, University of Leeds, Eawag-Sandec, Wasteaware (2020). User Manual: Waste Flow Diagram (WFD): A rapid assessment tool for mapping waste flows and quantifying plastic leakage. Version 1.0. February 2020. Principal Investigator: Velis C.A. Research team: Cottom J., Zabaleta I., Zurbruegg C., Stretz J. and Blume S. Eschborn, Germany. Obtain from: <http://plasticpollution.leeds.ac.uk>

**Copyright:**

Waste Flow Diagram - A rapid assessment tool for mapping waste flows and quantifying plastic leakage potential in cities by GIZ is licensed under Creative Commons CC BY-ND 4.0. To view a copy of this license, visit <https://creativecommons.org/licenses/by-nd/4.0>

This license requires that (re-) users give credit to the creator. It allows them to copy and distribute the material in any medium or format in unadapted form only, even for commercial purposes.

**Cover Photo:**

Copyright © Vincent Kneefel / WWF-NL

**Acknowledgment:**

The development of the Waste Flow Diagram has been made possible partly by funding provided by the German Federal Ministry for Economic Development and Cooperation (BMZ).

Experts from Gesellschaft für Internationale Zusammenarbeit GmbH (GIZ), University of Leeds, Eawag-Sandec and Wasteaware Ltd. developed this methodology. External experts from public and private sector gave support and advice during the development. The developer team wishes to express sincere thanks to the collaborating experts: Ellen Gunsilius, Johannes Paul and Pascal Renaud (GIZ) and Anne Scheinberg (Springloop). Great appreciation is expressed to external reviewers namely Prof. D.C. Wilson, Andy Whiteman and David Lerpiniere for feedback and shared valuable knowledge. Additionally, gratitude is expressed to the University of Leeds Digital Education Service and ETH Studios for their support in creating accompanying e-learning videos.

**Encouragement to share data and approach developer team:**

The development team encourages users of the WFD to share the results of their work with the developer team. This has a number of mutual benefits such as, supporting users in applying of the WFD, help to provide quality assurance, increase the availability of data for both waste management and marine litter, improve the robustness of the WFD and finally build a community of practice for data driven marine litter prevention. Feel warmly invited to contact the development team at [wfd.plasticpollution@leeds.ac.uk](mailto:wfd.plasticpollution@leeds.ac.uk) or find more information under STEP G.

<b>1. WASTE FLOW DIAGRAM OVERVIEW</b>	<b>5</b>
INTRODUCTION	5
TARGET AUDIENCE	6
USER REQUIREMENTS	6
<b>2. KEY CONCEPTS</b>	<b>8</b>
WASTE	8
MUNICIPAL SOLID WASTE (MSW)	8
MUNICIPAL SOLID WASTE MANAGEMENT (MSWM)	8
FORMAL WASTE MANAGEMENT	8
INFORMAL WASTE MANAGEMENT	9
MSWM SYSTEM STAGES	9
UNMANAGED WASTE	12
UNCOLLECTED WASTE	12
FATES	13
<b>3. THE WASTE FLOW DIAGRAM MODEL</b>	<b>14</b>
MODEL STRUCTURE	14
SIMPLIFICATIONS	16
EXCEL-BASED MODEL AND USER INTERFACE	16
LINK TO SDG INDICATORS	20
<b>4. STEP BY STEP GUIDE</b>	<b>22</b>
STEP A: GETTING STARTED	23
STEP B: COLLECT MSWM DATA	26
STEP C: QUANTIFYING PLASTIC LEAKAGE	33
STEP D: DETERMINE FATES OF PLASTIC LEAKAGE	49
STEP E: BUILD AND COMPARE SCENARIOS (OPTIONAL)	64
STEP F: RESULTS	65
STEP G: SHARING YOUR RESULTS	70
<b>ANNEXES</b>	<b>71</b>
ANNEX 1: ELEMENTS WITHIN THE SYSTEM MAP	71
ANNEX 2: EXAMPLE LEAKAGE ASSESSMENT FOR TRANSPORTATION	77
ANNEX 3. LEVELS OF CONTROL FOR SOLID WASTE MANAGEMENT FACILITIES	80
<b>REFERENCES</b>	<b>82</b>

# 1. Waste Flow Diagram Overview

## Introduction

The adequate collection and disposal of municipal solid waste (MSW) is a global challenge, particularly impacting low- and middle-income countries, as recognised by its inclusion in the United Nations Sustainable Development Goals (SDG 11 “Sustainable cities and communities”). Indicator 11.6.1 aims to monitor the “*proportion of municipal solid waste collected and managed in controlled facilities out of total municipal solid waste generated by cities*”. According to current estimates, 2 billion people worldwide have no access to waste collection services, and 3 billion people’s waste is managed in an environmentally unsound manner (Wilson et al., 2015). This has severe impacts both on human health and the environment, with one rapidly emerging problem being plastic pollution.

Plastic pollution is a reality and affects all ecosystems of our planet. It causes severe danger to animals, it blocks drains and waterways triggering and worsening floods, it degrades landscapes, and is already present almost everywhere, including the food chain. More than 6,300 million tonnes of plastic have been produced since the 1950’s (Geyer et al., 2017), of which 360 million tonnes of plastic were produced in 2018 alone. All of this plastic eventually becomes waste. Currently only 9% of the total global plastic waste is recycled, while 12% is burned or incinerated. The remaining 79% accumulate on landfill sites or the natural environment.

Oceans are thought to be a major final sink for some of this plastic as about 80% of marine litter are believed to derive from land-based sources (Eunomia, 2016). For macroplastics, this is largely as a result of a lack of waste collection infrastructure and poor waste management practices, particularly within low- and middle-income settings. Furthermore, increasing populations and consumption of resources exasperates these issues, with a need to better promote reduction, reuse and recycling within solid waste management (SDG - 12.5). Once in the ocean, the larger macroplastic items undergo degradation into innumerable secondary microplastics that are beyond any control and have deadly impacts on marine life and the health of the oceans (SDG - 14.1). It is therefore paramount to prevent macro plastic pollution at source, before it becomes uncontrolled in the environment, and potentially enters waterbodies.



**Figure 1: Adequate solid waste management is linked to a number of SDG indicators**

Fig 1 includes: 11.6 – by 2030, reduce the adverse per capita environmental impact of cities, including by paying special attention to air quality and municipal and other waste management; 12.5 – by 2030, substantially reduce waste generation through prevention, reduction, recycling and reuse; and 14.1 – by 2025, prevent and significantly reduce marine pollution of all kinds, in particular from land-based activities, including marine debris and nutrient pollution.

Many efforts are underway to try to reduce plastic pollution entering oceans, including beach clean-ups, bans on single-use plastics, and the continued development of reuse and recycling options. However, for countries to adequately meet these SDG targets, an important step is to understand the municipal solid waste management systems and practices, particularly those that may lead to plastic being released into the environment and identify the high priority areas to intervene.

The tool introduced in this document is the **Waste Flow Diagram (WFD)**. It was developed through a collaboration between GIZ, the University of Leeds, Eawag and Wasteaware. The aim of the WFD is to provide a rapid assessment methodology for mapping the flows of macro waste in a municipal solid waste management system at the city or municipality level, including quantifying the sources and fate of any plastic pollution. This aim can be summarised into six objectives:

- 1) To provide a rapid assessment of a cities or municipalities municipal solid waste management system and visualise the flows of waste, including informing the SDG 11.6.1 sub-indicators
- 2) To use observational based assessments to quantify the sources of plastic leakage into the environment from the municipal solid waste management system, and determine the eventual fate of this uncontrolled waste
- 3) To identify the high-priority sources of plastic pollution so as to make informed interventions
- 4) To allow benchmarking and comparison between cities
- 5) To run scenarios with the aim of gaining approximate insights into how proposed interventions may impact the solid waste management system and plastic pollution
- 6) To quantify the effectiveness of applied interventions

Whilst there are other ongoing initiatives with similar scope, such as the ISWA Plastic Pollution Calculator, the Waste Flow Diagram is targeted as a first-level approximation, whereby detail and accuracy of the analysis is traded for a more rapid assessment with fewer data requirements.

## Target audience

This manual is for individuals or organisations, such as:

- Local authorities wanting to understand waste flows within municipal solid waste management systems, estimate amounts of plastic leakage into the environment, and identify crucial areas to invest in their solid waste management infrastructure
- Development and donor agencies supporting capacity development and funding for solid waste management to improve the understanding of project impacts
- Non-Governmental Organisations (NGOs) and civil-society organisations wanting to make an improvement in the solid waste sector
- Entrepreneurs and private investors intending to set up waste collection, treatment or disposal activities as a business venture or social enterprise
- Any stakeholder, public, private, organisations or individuals concerned with solid waste management and plastic pollution

## User Requirements

Although, this manual tries to avoid complicated calculations, software or complex statistics, some basic mathematical operations are required. All calculations can be conducted with any conventional

spreadsheet software (e.g. Excel) or a calculator. In order to successfully apply this model, however, it is recommended to appoint users with substantial waste management experience. Further guidance and training is available through online courses<sup>1</sup>.

To use the tool, the user needs to insert data on the municipal solid waste management of the locality under assessment. Cities and towns without updated and reliable waste data are encouraged to conduct primary data collection exercises, for which the methodology of SDG indicator 11.6.1 ("measurement of total municipal solid waste generated, collected and managed in controlled facilities") is strongly recommended. The WFD tool is designed to directly integrate with this methodology. A step by step guide to the WFD data collection methods is given in Section 4.

---

<sup>1</sup>Online video guides for the Waste Flow Diagram tool are available at: <http://plasticpollution.leeds.ac.uk>  
The course "Municipal Solid Waste Management in Developing Countries" is available for free on the learning platform Coursera: [www.coursera.org/learn/solid-waste-management](http://www.coursera.org/learn/solid-waste-management)

## 2. Key concepts

### Waste

Waste refers to any substance or object generated as a result of human activity that is not a product (that is, a good or service resulting from a production process and intended for sale) for which the generator has no further use in a production, transformation or consumption activity and which, whether by choice or by legal requirement, is or is intended to be discarded. These substance or objects could become subject to resource recovery, recycling or reclamation activities as well as direct re-use or alternative uses, without or with only nominal remuneration.

### Municipal Solid Waste (MSW)

MSW refers to waste generated by households, and waste of a similar nature generated by commercial premises, by institutions such as schools, hospitals, care homes and prisons, and from public spaces such as streets, markets, slaughter houses, public toilets, bus stops, parks, and gardens. It also includes bulky waste (i.e. white goods, old furniture, mattresses) and waste from selected municipal services such as waste from street cleaning services (street sweepings and content of litter containers).

MSW should exclude construction and demolition waste as well as waste from municipal sewage network and treatment.

Most common sources of MSW are:

- **Household waste** refers to waste generated by household units.
- **Commercial waste** refers to waste of a similar nature to household waste generated by hotels, restaurants, shops/shopping areas, markets/supermarkets, slaughter houses and offices.
- **Institutional waste** refers to waste of a similar nature to household waste generated by schools, hospitals, care homes, prisons and government offices.
- **Waste from public places** refers to waste of a similar nature to household waste discarded in public places such as streets, squares, parks and gardens, unused plots of land, public toilets and bus stops, often referred as street sweepings.

In case a local definition of MSW is used instead, it is important to annotate the local or national definition(s) of MSW in order to facilitate future comparability.

### Municipal Solid Waste Management (MSWM)

*MSWM* is the set of activities carried out by formal and informal economic units, both public and private, and by generators for the purpose of the prevention, collection, transportation, treatment and disposal of waste. Waste management includes only controlled waste-related activities (both formal and informal).

### Formal waste management

Formal waste management relates to waste management activities undertaken by units working within the context of the formal economy; that is, organisations or individuals registered as economic units with government authorities and assumed to generally abide by local laws and regulations related to wastes and their management. Units in any economic sector, public or private, can be involved in formal waste management. Activities carried out by generators that are related to



management of their own wastes (for example, separation of recyclable materials into different types in preparation for kerbside collection) are also considered formal activities.

Formal waste management activities must be legal. It should be noted, however, that not all activities undertaken by organisations/individuals registered as formal economic units are necessarily legal, as even formal organisations/individuals can break laws.

## Informal waste management

The informal sector refers to individuals or enterprises who are involved in private sector recycling and waste management activities which are not sponsored, financed, recognised, supported, organised or acknowledged by the formal solid waste authorities, or which operate in violation of or in competition with formal authorities (Scheinberg et al., 2010).

Informal units are assumed to abide by local waste-related laws and regulations when it is in their interests to do so, but also to engage in illegal activities in some instances. Whether their activities are legal or illegal will depend on the laws and regulations in the jurisdiction in question. It may be the case, for example, that scavenging of waste (for example, used beverage cans) from household recycling bins set out for collection is legal in one jurisdiction but prohibited in another.

### Informal service chain

The informal service chain relates to the section of the informal sector which provide waste collection services. This is likely to be provided for a fee to areas which otherwise would have no waste collection. Although the primary motivation is provision of a service, the informal service chain may also separate valuable materials from their collection for sale.

### Informal value chain

The informal value chain relates to the section of the informal sector whose primary aim is to collect valuable materials for sale. Commonly referred to as “waste pickers” the informal value-chain operate typically in large parts of a city including areas such as dumpsites.

## MSWM system stages

The word “stages” is used to refer to each sequential activity within the MSWM system that the waste goes through, namely, generation, collection, sorting, transportation and disposal (see Figure 2).



Figure 2: Simplified schematic of a MSWM system

## Generation

MSW generation is the total municipal solid waste generated by the population and their economic activities in the system boundaries of the respective case study<sup>2</sup>. This MSW generation is further divided into six different waste fractions (paper, plastics, glass, metals, organics and other) which are modelled within the Waste Flow Diagram tool<sup>3</sup>.

## Collection system

The collection system refers to the amount of MSW generated that is moved from the point of generation such as specific addresses or designated collection points to the point of preparation for recovery, recovery facilities or disposal. The remaining share of MSW generated is considered “uncollected”. Collection systems are sometimes split into two parts; primary and secondary collection.

**Primary collection service** removes waste from the generators. It is often conducted manually or with simple vehicles from areas of high population density, with difficult access roads often un-paved and narrow. Primary collection delivers waste to the so-called collection points or transfer stations.

**Secondary collection service** collects waste from the transfer stations and transports it to the next waste management activity (e.g. treatment or disposal). Normally the vehicles are motorised and have big load capacities.

## Sorting

Sorting is defined as the exercise of separating materials with high value from the materials with low value, for the purpose of potential recovery (*see definition of recovery*). Sorting might occur in recognised formal facilities, or informally at all kinds of facilities (e.g. sorting plants, recovery plants, and disposal sites).

The WFD assumes that the highest rejection of materials occur at the first point of sorting. After this initial sorting, the rejects are believed to be greatly reduced due to the financial value of recycling the separated materials. Likewise, after the first point of sorting, material may be exported to other cities, regions or countries for recovery. As this would extend the data requirement beyond that of the city being studied, the WFD sets its system boundary to end at the first point at which waste is sorted with the intention for it to be recovered. As the WFD does not measure the waste up until its eventual recovery, the recycling rate stated by the WFD is only a proxy to the actual recycling rate.

In the case of formal sorting facilities, these would be mechanical biological treatment plants (MBTP) or sorting facilities where source separated plastics are separated from impurities (rejects). In the case of informal sorting facilities these would only exist when mixed waste is collected informally and valuable materials are extracted on the side of the road or from transportation vehicles.

## Transportation

Transportation refers to the movement of the MSW between the stages of the MSWM system. Depending on the waste management system, this may be done a number of times, and be regarded as either primary or secondary definition (*see definition of collection system*).

---

<sup>2</sup> See Step A1 in Chapter 4

<sup>3</sup> The 11.6.1 methodology used to calculate waste generation differentiates 12 waste fractions: 1. Kitchen/canteen, 2. Garden/park, 3. Paper/card, 4. Plastic-film, 5. Plastic-dense, 6. Metals, 7. Glass, 8. Textile/shoes, 9. Wood, 10. WEEE, 11. HHW, 12. Other (including hygienic products). The WFD groups these into simpler categories (organic = 1 & 2; plastic = 4 & 5; other = 8, 9, 10, 11, 12). The plastic fraction includes plastic packaging waste and other items primarily composed of plastic. This therefore excludes multi-material items which may only contain a small amount of plastic.

## **MSW management facilities**

MSW management facilities refer to collection points that receive municipal solid waste previously collected. This manual classifies these facilities into two big groups (based on SDG 11.6.1 methodology (UN-Habitat, 2020): recovery facilities (including facilities that prepare for recovery) and disposal facilities (Figure 3). Annex 3 introduces the ladders used to classify MSW management facilities according to their level of control.

### **Disposal**

Disposal refers to any operation that is not recovery even where the operation has as a secondary consequence including the reclamation of substances or energy, e.g. picking of materials for recycling at a land disposal site or recovery of landfill gas (Figure 3).

**Disposal Facilities** refer to disposal sites which are regularly (i.e. daily) used by the public authorities and private collectors, regardless of their level of control and legality. Such sites may or may not have an official recognition (license). Also, they may be managed in either a controlled or uncontrolled manner. Disposal sites in this assessment exclude other unrecognized grounds by the public authorities which accommodate minor amounts occasionally. Public authorities may organise clean ups to remove the waste from these disposal sites. Amounts diverted to such sites categorise as uncollected waste for the purpose of this assessment.

### **Recovery**

Recovery is defined as any waste management operation that diverts a waste material from the waste stream and which results in a certain product with a potential economic or ecological benefit. There are countless types of recovery facilities (OECD/Eurostat). Figure 3 provides the classification followed in this guide.

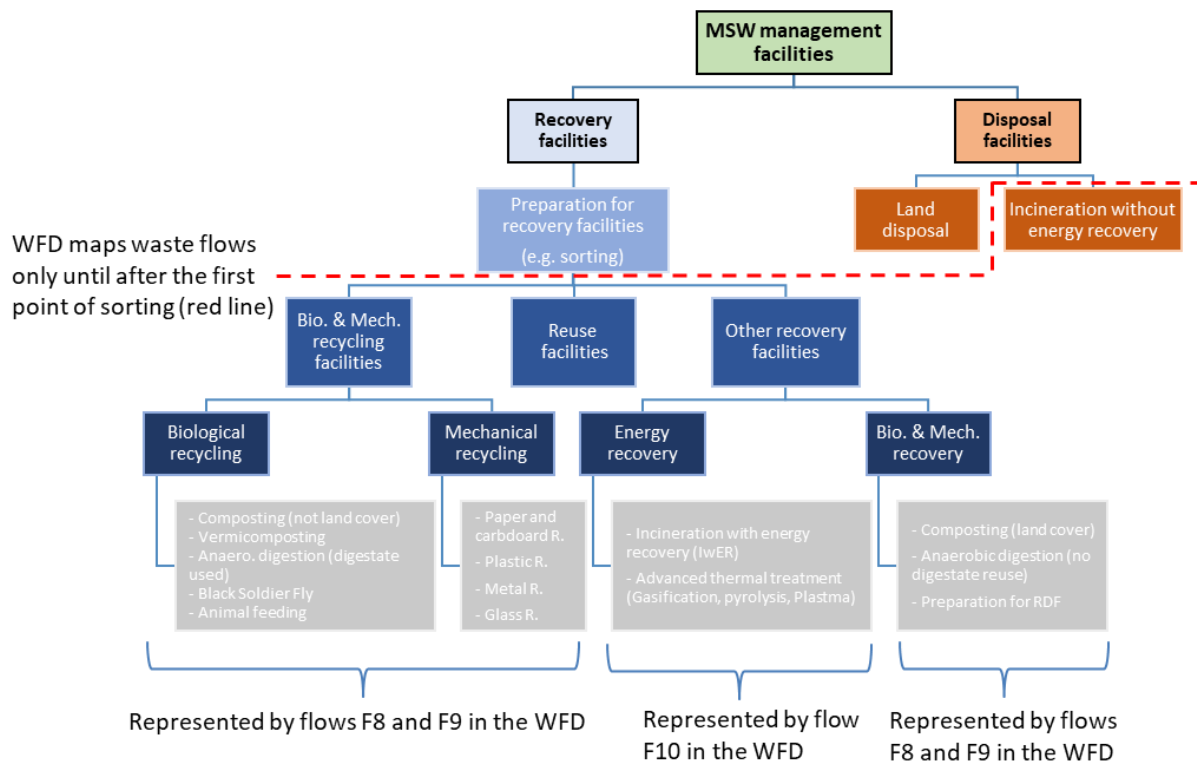

**Figure 3: Classification of recovery and disposal facilities. Amounts intended for biological or mechanical recycling or recovery, are represented by flows F8 (formal) and F9 (informal) in the Waste Flow Diagram system map (Figure 4). These flows combine all amounts that are sorted for recovery, without specifying the type of recovery facility the materials go to. The red line indicates the point at which the waste flow diagram (WFD) no longer specifies the destination of the flows of waste. Waste intended for energy recovery is represented by flow F10.**

## Unmanaged waste

Unmanaged waste refers to the fractions of waste that are not dealt within the MSW management system, making it difficult to estimate either the size of the problem or the scale of the associated costs. It consists of uncollected waste and waste that leaks out from the solid waste management system, both intentionally and non-intentionally, as well as illegally dumped waste in the environment.

## Uncollected waste

Uncollected waste refers to all waste generated which does not end up in either a recovery or disposal facility. The WFD model calculates the uncollected waste through mass balance, by subtracting the amounts that arrive in recovery and disposal facilities from the total MSW generated.

## Plastic leakage

Plastic leakage refers to plastics that escape from the waste management system becoming unmanaged but excludes uncollected plastics which is treated separately. The aim of the WFD is to quantify these leakages for every stage of the MSWM system. Within the WFD, only macroplastic leakage is considered and therefore excludes microplastic leakages. This is due to the solid waste management system primarily dealing with macro-sized waste items. Additionally, macroplastic leakage is deemed the critical focus area due to both the damage it causes once released uncontrolled into the environment and due to macroplastic items degrading into microplastic once in the environment.



## **Unmanaged plastic waste**

Unmanaged plastic mainly consists of uncollected plastics and plastics that leak out from the solid waste management system, both intentionally and non-intentionally, as well as illegally dumped plastic waste in the environment.

## **Plastic pollution**

Plastic pollution refers to the adverse effects that unmanaged plastic waste has on the environment, wildlife, humans and infrastructure. This includes impacts within all environments (land, air, water) including but not limited to that on marine ecosystems (marine plastic litter).

## **Fates**

**Fates** represent the locations where the unmanaged plastic is retained (sinks). The WFD considers four default fates: burnt, land, storm drains, and water systems; with the latter one being the fate of interest for marine litter monitoring.

### **Water systems**

We define water systems as any permanent body of water including rivers, canals, lagoon, lakes which drain into a river network or the ocean. Although not all plastic entering waterbodies may reach the ocean, there is a high chance for it to do so harming aquatic and marine life. Therefore it is defined here as marine litter.

### **Storm drains**

Storm drains in the context of this tool are defined as any natural or man-made channel that drains excess rain or ground water, and which does not have a continuous flow of water. This includes seasonal riverbeds, drains at sidewalks, built in canals, etc. but excludes plastics in the sewage system drains, unless they are combined (e.g. open rain water and sewage systems). Only plastic which is removed (cleaned) from storm drains is accounted under this fate. Anything not removed is assumed to eventually reach water systems and is accounted under the water systems fate.

### **Land**

Land in the context of this tool refers to all surface types where plastic will remain entangled, trapped, or have reduced mobility and little chance to reach water bodies or enter the management system again (e.g. wild dumpsites, dense vegetation, burying etc.). This also includes any plastic waste that originally was on land but has subsequently been collected by street sweeping activities.

### **Burnt**

Burnt accounts for plastic waste openly burnt as a disposal method (i.e. burning of uncollected waste by residents, or burning of sorting rejects). Burning as a fate only applies to the unmanaged portion of plastics, therefore those that are uncollected or have leaked from the MSWM system. This excludes plastic burnt by residents for fuel (as this is not considered as waste), burning that occurs at dumpsites (as it is not regarded as a leakage) or burning that occurs in dedicated facilities such as incinerators (as this is accounted for by the energy from waste flow).

### 3. The Waste Flow Diagram model

In this chapter you will learn about the excel-based WFD model. The structure of the model is introduced along with the underlying simplifications considered for its development. Additionally, the user interface of the excel-based model is discussed, before specifying the linkage with the SDG indicator 11.6.1 and its accompanying methodology.

#### Model structure

The WFD maps the flows of waste according to the system diagram shown in Figure 4. The model is presented according to a Material Flow Analysis where each box represents a process (stage or fate) and arrows represent the mass flows in-between.

There are two types of boxes:

- **Blue boxes** represent stages within the municipal solid waste management system, including those operated by the informal sector. This includes generation, collection, treatment, transport and final disposal.
- **Yellow boxes** represent waste that has leaked from (or never entered in the case of uncollected waste) the MSWM system, and as such ends up in the environment. The model distinguishes four **fates** namely, openly burnt, retained on land, removed from drains, and entering water systems.

The flows in the system map show the possible pathways waste follows from its point of generation through to its eventual disposal, treatment or fate in the environment. All flows are quantified in the WFD in tonnes per annum. There are also two types of arrows:

- **Green arrows** represent municipal solid waste flows, whereby all major materials are modelled (organics, plastics, paper, glass, metal and other).  
**Orange arrows** represent plastic leakage flows. Being predominantly concerned with plastic pollution, the WFD only calculates the amounts of plastic leaked. All factors and transfer coefficients therefore specified for these orange flows are relative to plastic only.

A detailed description of each process and flow is discussed in Annex 1: Elements within the system map.

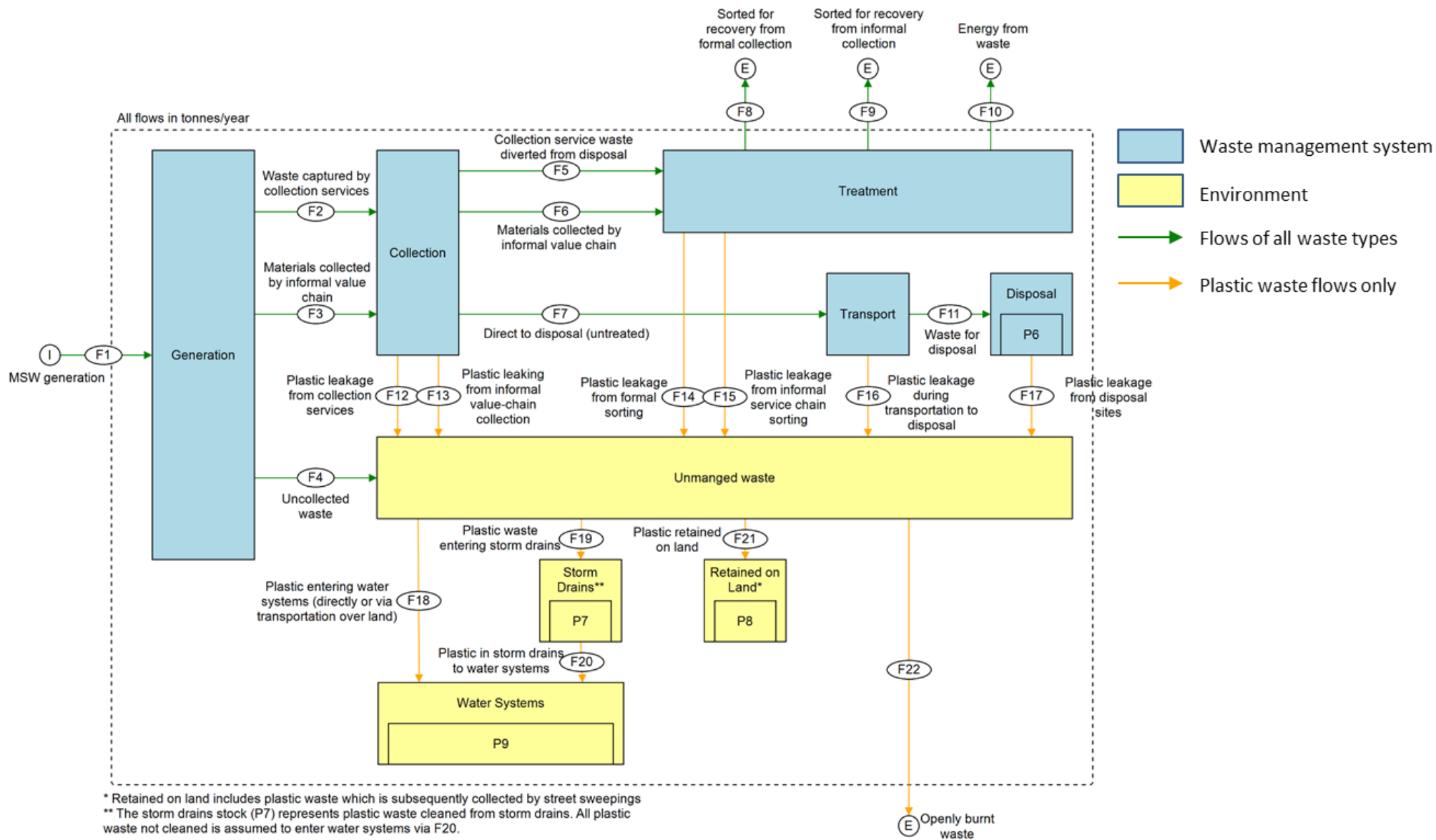

Figure 4: Waste Flow Diagram system map for municipal solid waste and plastic flows

## Simplifications

Importantly, the system map shown in Figure 4 is not intended to show all possible flows of waste, but instead takes a linear approach following the general waste management stages of generation, collection, treatment, transport and disposal. This means that some flows of waste, which may occur in real-life, are not shown on the system map as these go against the order of the waste management stages and would cause loops and double counting in the system (see example).

Nonetheless, these flows are still accounted for, but instead applied linearly, in a similar manner to that of “shit flow diagrams”. For instance, using the above example, flow F3 accounts for all valuable waste materials collected by the informal value chain sector, regardless of collection location and F8 and F9 accounts for formally and informally separated material for recovery. Bearing this in mind, it is important to remember that the system map is simply a visualisation tool to allow target areas to be identified and waste flows to be monitored.

Further, the fate only show the final fate and do not track waste flows between fates (e.g. plastic on land which is transported to water systems is allocated only to water systems). Although significant time variations occur in plastic transportation depending on the season and local weather, these fluctuations are assumed to be included in the transfer coefficient applied, with the flow results reported in units of tonnes per year.

**Example:** The informal value-chain often collects valuable material from disposal sites and would transfer this to the treatment process box in the system map for further sorting or reprocessing. However, this flow is deliberately not represented within the system map. This is due to all informal value-chain collection being represented by flow F3, regardless of the actual collection location. This approach is followed as the data collection methods identify the total waste collected by the informal value-chain but not where this material was originally sourced from. This simplification therefore does not mean that certain flows are not accounted for, but instead simplifies the data requirements.

## Excel-based model and user interface

The WFD is an excel-based model comprised of 6 sheets:

- 1) Baseline data entry
- 2) Scenario data entry
- 3) Calculations
- 4) Flow diagrams
- 5) Results summary
- 6) Settings



## Baseline Data Entry

The “baseline data entry” sheet (Figure 5) provides the user interface for entering the data required in order to run baseline assessments. These baseline assessments aim to use primary data collection and local on-the-ground observations of the waste management system to map the current flows of waste within the municipal solid waste management system. It includes a first approximation of the plastic pollution within the area. The improved understanding of the sources, pathways and fates of plastic pollution, will hopefully aid in successfully identifying where to apply interventions. The baseline assessment further allows benchmarking and comparison with other cities or municipalities. Additionally, by linking with the SDG 11.6.1 methodology for “measurement of total municipal solid waste generated, collected and managed in controlled facilities”, results can be obtained for these SDG sub-indicators.

The “baseline data entry” sheet consists of 8-9 columns with each row indicating a separate data entry. In total, there are 5 main input sections as listed below,

- 1) Waste generation information
- 2) Waste treatment and disposal
- 3) Managed in controlled facilities
- 4) Plastic leakage potential levels per leakage influencer
- 5) Plastic pollution levels per fate

**Orange and blue cells** mark the sections, with these further broken down in 21 individual data questions, numbered within the first column. **White cells** provide information on the data input, whilst **green cells** highlight the location data needs to be entered into the tool. **Grey rows** provide a visual calculation error check for the user, as explained in their corresponding notes column. These rows are conditionally formatted to turn red in the event of a suspected error, in which case the data inputs should be checked and corrected. The **ⓘ symbol** represents cells which when clicked provide pop-up information relating to the data input.

NOTE: All percentage units are in terms of weight % Click the ⓘ symbols for more information and definitions

1. Waste generation information		Baseline			Data Reliability ⓘ		
No.	Item	Description	Unit	Value	Information ⓘ	Metadata ⓘ	Value
1	Population ⓘ	How many people live in the area (city, urban district, region) you want to model?	Persons		Please use an estimate based on the last census or other official data.		
2	Municipal solid waste generation per capita ⓘ	How much municipal solid waste per person is produced per day?	Kg/capita/day		This value should be measured at source using waste characterisation exercises as explained in the user manual. As a last resort, please use values from comparable areas.		
3.1	Municipal solid waste composition ⓘ	Paper	Weight-%		In the absence of waste characterisation data, default values by income level may be used: <b>High Income:</b> Paper = 24%, Plastics = 11%, Glass = 6%, Metals = 5%, Other = 20%, Organic = 34% <b>Upper Middle Income:</b> Paper = 19%, Plastics = 12%, Glass = 5%, Metals = 4%, Other = 14%, Organic = 46% <b>Lower Middle Income:</b> Paper = 11%, Plastics = 9%, Glass = 3%, Metals = 3%, Other = 21%, Organic = 53% <b>Low Income:</b> Paper = 6%, Plastics = 7%, Glass = 2%, Metals = 2%, Other = 30%, Organic = 52% (Source: UNEP, 2015. Global Waste Management Outlook)		
3.2		Plastics	Weight-%				
3.3		Glass	Weight-%				
3.4		Metals	Weight-%				
3.5		Other	Weight-%				
3.6		Organic	Weight-%				
--	Total	%		0%	Must be = 100%		
2. Waste treatment and disposal		Baseline			Data Reliability ⓘ		
No.	Item	Description	Unit	Value	Information ⓘ	Metadata ⓘ	Value
4.1	How much MSW is disposed of in designated disposal sites? ⓘ	Paper	Tonnes/day		The methodology behind measuring the amount and composition of waste disposed of in designated disposal sites is outlined within the user manual.		
4.2		Plastics					
4.3		Glass					
4.4		Metals					
4.5		Other					
4.6		Organic					
5.1	How much MSW is sent to energy from waste? ⓘ	Paper	Tonnes/day		The methodology behind measuring the amount and composition of waste sent to energy recovery is outlined within the user manual.		
5.2		Plastics					
5.3		Glass					
5.4		Metals					
5.5		Other					
5.6		Organic					
6.1	How much MSW is sorted by the formal sector for recovery? ⓘ	Paper	Tonnes/day		Both the formal and informal recycling systems are often integrated with one another, making identification of the contribution of each difficult. The user manual gives details on how to measure the amounts sorted by each sector respectively.		
6.2		Plastics					
6.3		Glass					
6.4		Metals					
6.5		Other					
6.6		Organic					
7.1	How much MSW is sorted by the informal sector for recovery? ⓘ	Paper	Tonnes/day		Here we define the formal sector as those registered or licensed by the municipality (i.e. have a contract with the municipality). Alternatively, the informal sector is defined as those unregistered or not licensed by the municipality. Only informal value-chain workers (i.e. not performing collection services) are counted here. This is due to informal collection services which transfer waste to the formal sector being considered under formal activities. Waste collected by informal collection service which do not transfer the waste to the formal sector but instead dump / burn the waste, is likewise considered as uncollected waste.		
7.2		Plastics					
7.3		Glass					
7.4		Metals					
7.5		Other					
7.6		Organic					
8.1	Informal service chain collection ⓘ	Do the informal collection services (service chain) separate plastic for recovery?	NA		Plastics may be separated by the informal service chain from the mixed waste they collect chain to supplement their income.		
8.2		What percent of the mixed waste collection was collected by informal collection services?	% of waste collected by collection services		If data is unavailable on the split between the informal and formal collection services, please use the percent of the study area covered by informal collection services compared to the formal sector as a proxy. See the user manual for details.		

Figure 5: Structure of the Waste Flow Diagram model “Baseline data entry” sheet.

For the data input section “1. Waste generation” and “2. Waste treatment and disposal”, the SDG 11.6.1 indicator of collection coverage is not required. This is due to the collection coverage being calculated automatically by the WFD based on the amount of waste measured at treatment and disposal sites, compared to the estimated amount generated at source. Please refer to the SDG 11.6.1 methodology for more details (UN-Habitat, 2020).

In data input sections “4. Plastic leakage potential levels” and “5. Plastic pollution levels”, some inputs have to be chosen from a set of predefined values in form of a drop-down menu. This is to ensure inputs are entered in the standardised format.

In section “5. Plastic pollution levels” there is also one additional column called “**normalised fate (%)**” showing the percentage allocated to each fate based on the selection chosen in the dropdown boxes. These fates are normalised for each process to 100% based on the allocation of other fates for that process. Please refer to “Step D: Determine fates of plastic leakage”, in section 4 of this user manual to understand the process behind the score of each fate. If detailed information on fates already exists, the selected value can be altered to match this measured value.

The “Data Reliability” column refers to the confidence you have in the data.

- **High** should be selected when primary data collection has been performed according to the methods described in the user manual and you are confident with the results.
- **Medium** should be selected if you are using recent data but it has not been collected specifically for this project using the methods outlined in the user manual (e.g. feasibility studies of other projects in the same region and similar socio-economic profile). Alternatively, medium could be selected if you have followed the primary data collection methods, but believe it may have some inaccuracies or are less confident with the result.
- **Low** should be selected if you are using old data or ones which the original source or method is unclear. Likewise, choose this option if you are highly uncertain over the accuracy of the value, or if the value was an assumption.

### Scenario data entry

The “Scenario data entry” sheet follows the same logic and formatting as the “Baseline data entry” sheet (Figure 6), but differs with respect to its purpose and the associated data inputs.

The purpose of the “Scenario data entry” is to provide a means to allow users to estimate the potential impact of applying interventions within the waste management system, for instance by upgrading a disposal site, or improving collection coverage. These scenarios can be either based off the baseline assessment (with the inputs used for this shown for ease), or can alternatively be based off approximations by the user as a means to ‘test’ scenarios.

As with the “Baseline data entry” sheet, the data inputs are split into five sections, however, it should be noted here that some of the data inputs are different. For example, to allow users to assess how changes in collection coverage would impact the waste flows, the collection coverage is now included as an input, thereby different to the baseline assessment in which this is calculated according to other inputs.

Whilst users are able to alter the values in the data input section “5. Plastic pollution levels per fate”, this should only be performed for test purposes. If scenarios are being considered relative to the baseline, these fates should be left unchanged as they dictate where the unmanaged plastic ends up. The exception to this is if the user plans to increase the level of street sweeping or drain cleaning within an area, in which case the relative fates for the land or storm drains fate should be increased.

NOTE: All percentage units are in terms of weight % Click the (i) symbols for more information and definitions

1. Waste generation information			Baseline (i)	Scenario 1	Scenario 2	Scenario 3			
No.	Item	Description	Unit	Value	Value	Value	Value	Notes	Metadata (i)
1	Population (i)	How many people live in the area (city, urban district, region) you want to model?	Persons	0				Please use an estimate based on the last census or other official data and consider population growth rates for scenarios.	
2	Municipal solid waste generation per capita (i)	How much municipal solid waste per person is produced per day?	Kg/capita/day	0.00				This value should be measured at source using waste characterisation exercises as explained in the user manual. As a last resort, please use values from comparable areas.	
3.1	Municipal solid waste composition (i)	Paper	Weight-%	0%				In the absence of waste characterisation data, default values by income level may be used:  High Income: Paper = 24%, Plastics = 11%, Glass = 6%, Metals = 5%, Other = 20%, Organic = 34% Upper Middle Income: Paper = 19%, Plastics = 12%, Glass = 5%, Metals = 4%, Other = 14%, Organic = 46% Lower Middle Income: Paper = 11%, Plastics = 9%, Glass = 3%, Metals = 3%, Other = 23%, Organic = 52% Low Income: Paper = 6%, Plastics = 7%, Glass = 2%, Metals = 2%, Other = 30%, Organic = 53% (Source: UNEP, 2015. Global Waste Management Outlook)	
3.2		Plastics	Weight-%	0%					
3.3		Glass	Weight-%	0%					
3.4		Metals	Weight-%	0%					
3.5		Other	Weight-%	0%					
3.6	Organic	Weight-%	0%						
-	Total		%	0%	0%	0%	0%	Must be = 100%	
2. Waste collection, treatment and disposal			Baseline (i)	Scenario 1	Scenario 2	Scenario 3			
No.	Item	Description	Unit	Value	Value	Value	Value	Notes	Metadata (i)
4.1	What is the collection service coverage? (i)	All MSW	% of waste generated	RDV/DI				This includes only waste collected by the formal sector, or collected by informal collection services if they transfer it later to the formal system.	
5.1	How much MSW is collected by the informal value-chain sector for recovery? (i)	Paper	% of waste generated	RDV/DI				This includes only waste collected by the informal value-chain sector. This is due to informal service-chain collectors being included within the formal collection coverage as discussed above.	
5.2		Plastics	% of waste generated	RDV/DI					
5.3		Glass	% of waste generated	RDV/DI					
5.4		Metals	% of waste generated	RDV/DI					
5.5		Other	% of waste generated	RDV/DI					
5.6	Organic	% of waste generated	RDV/DI						
6.1	How much of the collected waste is sent to energy from waste? (i)	Paper	% of waste collected by collection services	0%				Includes incineration and advanced thermal treatments (gasification, pyrolysis etc.) but excludes the open burning of waste and the burning of waste as a fuel by residents.	
6.2		Plastics	% of waste collected by collection services	0%					
6.3		Glass	% of waste collected by collection services	0%					
6.4		Metals	% of waste collected by collection services	0%					
6.5		Other	% of waste collected by collection services	0%					
6.6	Organic	% of waste collected by collection services	0%						
7.1	How much of the collected waste is sorted for recovery? (i)	Paper	% of waste collected by collection services	0%				As the unit for this input is "% of waste collected by collection services", this excludes waste collected by the informal value chain. If assigning a value for this is difficult to obtain due to the integration of the formal and informal sorting, use the baseline value as an indicator.	
7.2		Plastics	% of waste collected by collection services	0%					
7.3		Glass	% of waste collected by collection services	0%					
7.4		Metals	% of waste collected by collection services	0%					
7.5		Other	% of waste collected by collection services	0%					
7.6	Organic	% of waste collected by collection services	0%						
8.1	How much of the collected waste is sent to designated disposal sites? (i)	Paper	% of waste collected by collection services	0%				Designated disposal sites (DDS) refer to disposal sites which are regularly used by the public authorities and private collectors, regardless of the level of control and legality. DDS can be officially designated or non-officially designated but still used regularly.	
8.2		Plastics	% of waste collected by collection services	0%					
8.3		Glass	% of waste collected by collection services	0%					
8.4		Metals	% of waste collected by collection services	0%					
8.5		Other	% of waste collected by collection services	0%					
8.6	Organic	% of waste collected by collection services	0%						
9.1	Informal service chain collection (i)	Do the informal collection services (service chain) separate plastic for recovery?	NA	0%				Plastics may be separated by the informal service chain from the mixed waste they collect chain to supplement their income.	
9.2		What percent of the mixed waste collection was collected by informal collection services?	% of waste collected by collection services	0%				If data is unavailable on the split between the informal and formal collection services, please use the percent of the study area covered by informal collection services compared to the formal sector as a proxy. See the user manual for details.	

Figure 6: Structure of the Waste Flow Diagram model “Scenario data entry” sheet.

## Calculations

The “Calculations” sheet processes the data inputs in order to map the flow of waste across the system. Although no data should be entered directly into this sheet, there are still some important aspects to consider. For example, the first column shows the flow ID as related to Figure 4 or the diagram in the “Flow Diagram” sheet. The flow name and material are then reported in the second column, before the calculations for the baseline, and scenarios are displayed respectively. A data reliability column is also included for each flow. This takes the qualitative data reliability inputs and calculates a score which depends both on that input and on any previous input on which that number is based. For example, if the amount of waste generated had low data reliability, all the subsequent flows of waste would also have a lower data reliability score as they would be based off this initial generation value. This allows the propagation of data reliability throughout the system, as shown by traffic light coloured indicators on the “Flow diagram” sheet.

The right-hand box shows a series of error checks that are performed on the calculations such as a system balance check, a negative check, and a mass balance checks for each process. The balance check ensures that the conservation of mass is retained, in that mass in = mass out + stock. The negative check on the other hand ensures no flows are less than zero anywhere in the system. If no errors are present, each cell will read zero and be white. If, however, an error occurs on the process mass balance or input data, the cell will turn red and the amount of mass causing the error will be displayed.

## Flow diagram

The “Flow diagram” sheet is split into two sections:

- 1) Waste Flow Diagram
- 2) Sankey Diagram

The first depicts the system map shown in Figure 4. It also includes live results relating to the values of each flow and the data reliability score (for baseline flows only). All flows are shown with the units

of tonnes per year. Through the drop-down boxes at the top, you can select the scenario or baseline as well as the type of waste to show (paper, plastics, glass, metals, other, organic or all MSW).

The second section is related to an automatically produced code that allows you to create a Sankey diagrams. This is an alternative, more intuitive visualisation output whereby the arrows are proportional to the mass. Depending on your needs, you can choose between a simple and a more complex diagram. The code is designed to be directly input into [www.sankeymatic.com](http://www.sankeymatic.com) with further instructions on the formatting and layout discussed in the model.

## Results summary

The “Results summary” sheet displays the most important information from each model run in an easy-to-compare and printer-friendly dashboard. Results are split into two sections (pages), the first relating to results of the waste management flows for both plastic only and all MSW. For example, details on collection coverage, recovery rates, energy from waste and amounts managed in controlled facilities are shown. These directly link with the SDG 11.6.1 sub-indicators. As discussed previously, the recovery rates are not to be used as official recovery rates as these only go to the first point of sorting, however, they are hoped to provide a good indication of what actual recovery rates may be.

The second, set of results focusses solely on the unmanaged plastic pollution, giving results on its sources, pathways and eventual fate. This includes the result on the amount of plastic entering water systems and therefore contributing to marine litter.

Further details on this section are also provided in the F1: Summary tables section.

## Settings

The “Settings” sheet contains the default non-user input data behind the model. Although this sheet is locked for editing, the transfer coefficients used can still be viewed for transparency. The settings included in this sheet are:

- Maximum potential leak values used in the unmanaged waste – amounts decision tree.
- Reduction potentials used in the unmanaged waste – amounts decision trees.
- Transfer coefficients used in the unmanaged waste – fate decision trees.
- Uncertainty factor used in quantifying data reliability
- Naming options for drop down menus

## Link to SDG indicators

### Link to SDG 11.6.1 – MSW regularly collected with adequate final discharge

The WFD tool is harmonised with the SDG indicator 11.6.1 meaning that you can directly use and visualise the data of the SDG indicator. This is particularly interesting for those users who opt to conduct primary collection of data using the SDG 11.6.1 methodology.

After entering all quantitative data required, the model automatically calculates the three sub-indicators of the SDG 11.6.1:

- Proportion of MSW collected<sup>4</sup>: This sub-indicator measures the total MSW collected in the city, including both informal and formal collection forms.

---

<sup>4</sup> Triangulation: It is strongly recommended to consider already existing waste collection estimates for triangulation. Check to what extent the available data diverts from the calculated figure. A difference of  $\pm 5-10\%$  is acceptable. If higher than that, double check your calculations and also the source of the available information. The SDG 11.6.1 calculates collection coverage on a mass basis (i.e. mass collected over mass generated). Many cities provide their collection coverages on population basis (i.e. population served with collection over total population). Differences observed when triangulating may be partly due to the different units.



- Proportion of MSW managed in controlled facilities: This sub-indicator measures the total MSW that is managed in facilities (either recovery or disposal) with at least “BASIC” control level.
- Plastic Leakage: This is the total amount of generated plastic that leaks from the MSWM system.

For further details on the two first sub-indicators please refer to the SDG 11.6.1 methodology.

In difference with WFD approach, the SDG 11.6.1 methodology considers recovery facilities to be the last facility of the value chain processing the materials within the system boundaries of the case study. These could be recycling companies, exporting companies or facilities which conduct the very first stage of sorting.

#### **Link with 12.5.1 - National recycling rate**

The WFD only considers the first stage sorting within the boundaries of the case study. As a consequence, the amounts of MSW recovered for recycling cannot be determined according to the definition set by SDG 12.5.1. This indicator only considers a fraction of the amounts allocated for recovery, e.g. those intended for recycling. Furthermore, SDG 12.5.1 measures the national recycling rate whereas the WFD operates at the city or municipal level.

#### **Link with 14. 1 - Reduce marine pollution of all kinds, in particular from land-based activities**

The WFD assessment of plastic leakage differs from the SDG 14.1 in that it looks at the source of plastic leakage within the MSW management system. This highlights where intervention are required within the system. Comparatively, SDG 14.1 assesses the presence of plastic in the environment, and when possible it provides some information on the type of plastic polymer, the manufacturer and the country of origin. Both assessments provide valuable information and are complementary.

## 4. Step by step guide

This chapter lays out all steps to follow when applying the WFD as summarised in Figure 7.

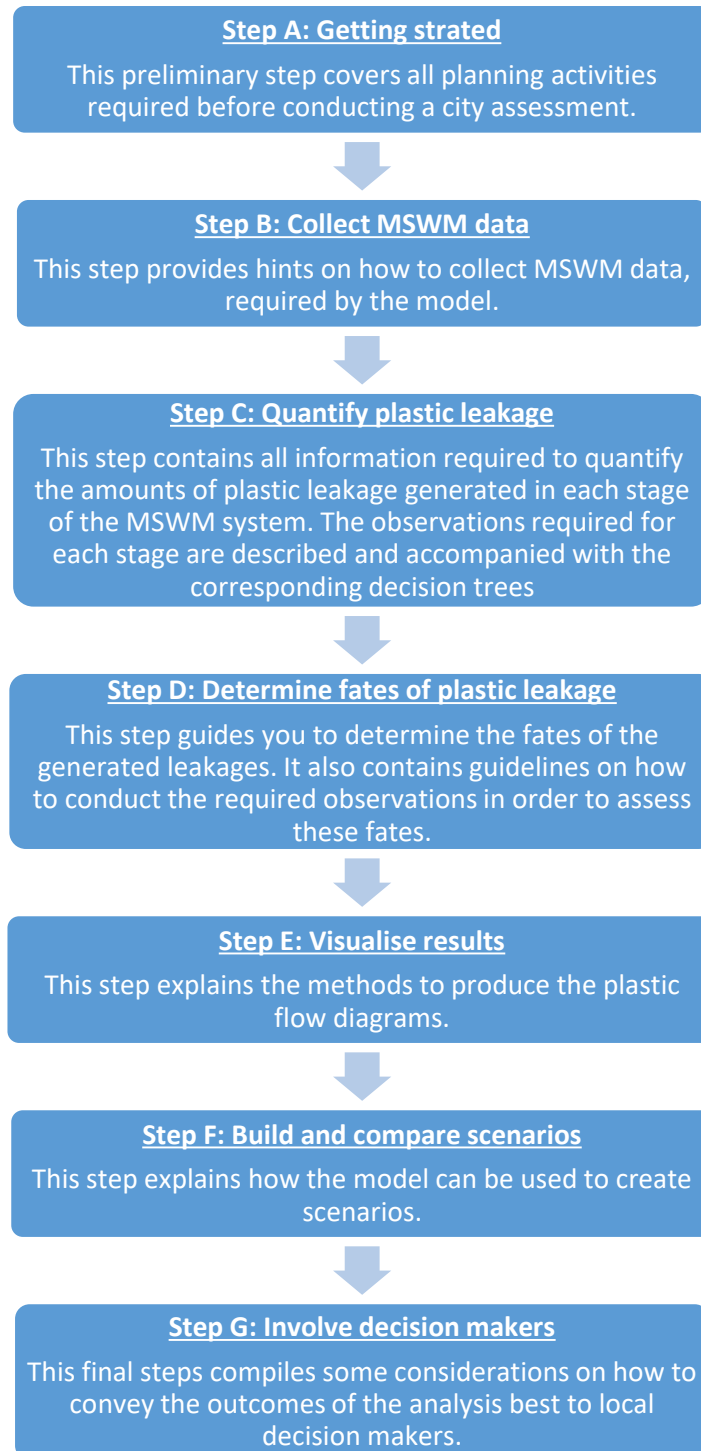

**Figure 7: Steps of the Waste Flow Diagram**

## Step A: Getting started

### A1 Define system boundary

When defining the system boundary, care should be taken that it is not too large to capture the variations in waste management adequately, whilst also not being too narrow to limit the potential impact of interventions. **It is recommended that the system boundary is set at the municipal level.** In cases where the service providers include areas outside of the official municipal border, and the waste generated in such areas cannot be separated from the main waste stream, these areas should also be accounted in the assessment.

### A2 Define data collection approach

Please keep in mind that prior to quantifying the plastic leakages with the WFD, the following quantitative information of the MSWM system needs to be compiled:

- 1) Population
- 2) MSW per capita generation
- 3) Composition of MSW
- 4) Amounts per material diverted from disposal for recovery
- 5) Split between the formal and informal collection of recyclables
- 6) Split between the service and the value chain for the informally sorted materials
- 7) Rejects from formal and informal sorting facilities
- 8) Amounts of materials going to disposal
- 9) Composition of disposed waste
- 10) Materials extracted from disposal facilities
- 11) Level of control of sorting and disposal facilities

Table 4 in Step B provides a description for all the data points required to run the WFD assessment. Ideally, this information should be as up to date and reliable as possible. Figure 8 presents all possible situations regarding the availability of MSWM data that users might encounter when doing this assessment.

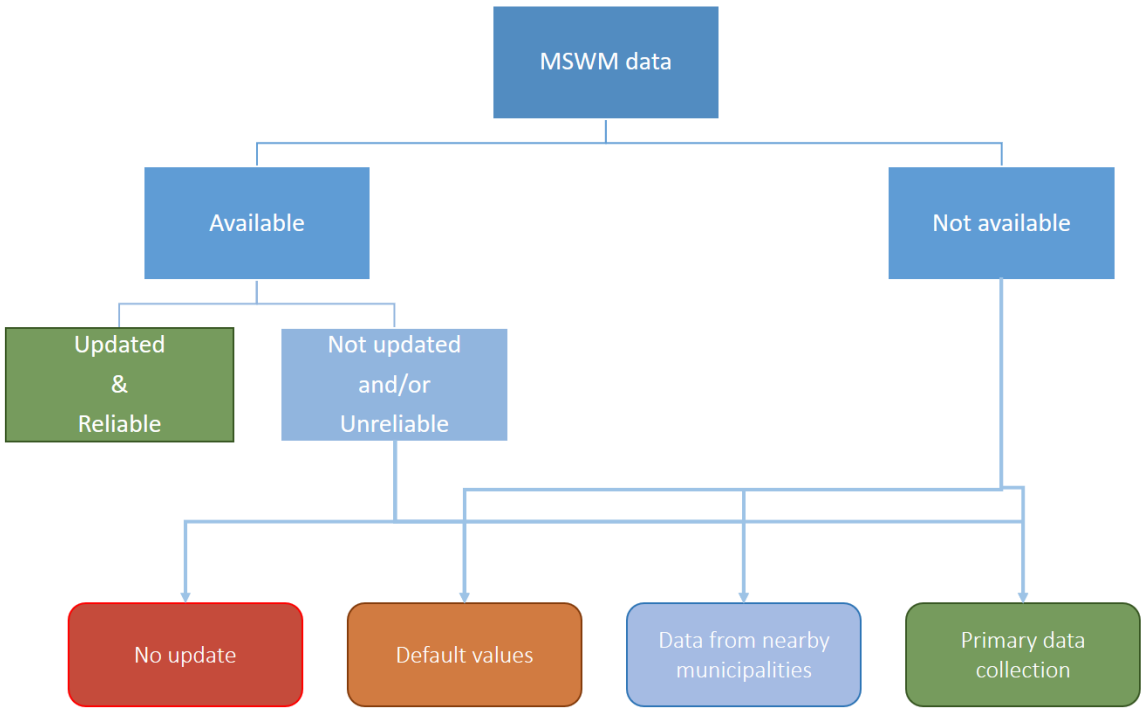

Figure 8: Data availability scenarios for users of the WFD.

If reliable and up-to-date MSWM data is not available, you have may choose among one of the four different approaches given in Table 1, ordered based on preference.

**Table 1: Data collection approaches for WFD assessment**

Approach	Description
1 <b>Primary data collection</b>	<p>This is the preferred option.</p> <p>In such cases we recommend the methodology of the SDG indicator 11.6.1, which measures total municipal solid waste collected and managed in controlled facilities with regards to the total waste generated by cities.</p> <p>Refer to section “Step B: Collect MSWM Data”</p>
2 <b>Data from nearby municipalities</b>	<p>In case reliable data from nearby municipalities is available, you may assume that the situation is very similar in your case study and use the same data. However, this option can only work for some specific data points, such as per capita generation of MSW (2), composition of generated MSW (3), composition of disposed waste (8) and percentage of rejects (6). Some of the other data points must originate from the case study: population (1), split between informal and formal collection (4), amounts of materials diverted to recovery (5), amount of MSW disposed (7).</p> <p><b>Note:</b> Mixing data from different municipalities might result in misleading results. For example, using composition data for generated and disposed MSW which originate from two different municipalities, might result in higher amounts of a given fraction at disposal than at generation.</p>
3 <b>Default values</b>	<p>The third option is to use default values from existing databases (Kaza et al., 2018, Wilson et al., 2015). This approach, however, can only be applied for some of the data points (2, 3).</p>
4 <b>No update</b>	<p>As a fourth option, you may use outdated or unreliable data.</p>

Users in need of better data must evaluate their resources (i.e. time, financial means and labour) and choose one of the approaches mentioned above. The data reliability must be assessed by the user and entered into the “Baseline data entry” sheet as discussed in section 3.

### **A3 Engage with local partners**

Before starting the fieldwork, it is highly recommended to get in touch with local partners with a good understanding of the local waste management situation. Ideally, this should be planned well in advance. 2 to 3 months are the minimum time period recommended for activating the local stakeholders and organising the fieldwork.

This step serves the following purposes:

- Getting familiar with the WFD methodology at an early stage
- Acquiring a solid understanding of the local context
- Preparing a tentative program for the field assessment
- Coordinating any potentially required permits and formalities

### **A4 Time requirements**

The time required for the data collection largely depends on the factors given in Table 2.

**Table 2: Factors influencing time requirements of the data collection**

Factor	Description
1 Availability of MSWM data	The availability of reliable, up-to-date data allows users to skip the MSWM data collection exercise. Only the WFD instructions will have to be completed.
2 Complexity of MSWM system	<p>If primary data collection is required, the complexity of a MSWM system influences the duration of the assessment. Complexity in this case relates to two aspects:</p> <p><b>1) Number of active service providers:</b> This often proportionally correlates with the size of the case study. A case study with more than 5 formal collection service providers for mixed MSW can be considered complex.</p> <p><b>2) Presence of the informal sector:</b> Case studies where mixed MSW is collected informally in parts of the city can be considered complex. If the informal sector supplies a big portion of the materials processed through the value chain, the case can also be considered complex.</p>
3 Data collection approach	If data is unavailable, sufficient time should be reserved for the MSWM data collection exercise. The choice of one of the approaches shown in Table 1 heavily influences the duration of the overall assessment.

Table 3 shows the different time and resource requirements for each possible scenario.

**Table 3: Time requirements and approximate team size during city assessment**

MSWM Data	Complexity	Data collection approach	Method	Time & team size*
Available	NA	NA	NA	1 week
				1 SWM expert
Not available	Complex	Primary data collection	SDG 11.6.1	1 month
				3 – 6 people*
		Nearby municipalities	Interviews	2 weeks
			Literature search	1 – 2 people
		Default	Interviews	2 weeks
	Literature search		1 – 2 people	
	Not complex	Primary data collection	SDG 11.6.1	2 weeks
				2 – 4 people*
		Nearby municipalities	Interviews	1 weeks
			Literature search	1 – 2 people
Default		Interviews	1 weeks	
	Literature search	1 – 2 people		

\* This excludes helpers needed for the waste composition exercises for household waste and disposed waste (for guidance see SDG 11.6.1. methodology).

## Step B: Collect MSWM Data

This section outlines the data requirements needed to run the WFD. If you are intending to assess a complex case study, you might be discouraged by the long list of items required. Don't panic. From a methodological perspective, most of these items are quite straightforward to obtain. The biggest constraint to compile this information are time and a team. We encourage you to give it a try!

The methodology published by UN-Habitat on how to measure SDG indicator 11.6.1 (UN-Habitat, 2020) will be of great help if you decide to conduct primary data collection. It includes the steps and materials (e.g. questionnaires) required to measure most of the data points needed to run the WFD. This user manual describes the steps required to estimate all remaining data points.

**Table 4: Data points required for the WFD assessment**

	Data point	Relates to WFD Baseline Input ID	Description	Method
1	Population	1	Total population of case study (i.e. city, municipality, metropolitan area)  Unit: Persons	SDG 11.6.1
2	Municipal solid waste generation per capita	2	This per capita generation should consider all MSW streams (i.e. household waste, commercial waste and institutional waste. Please refer to section definitions).  Unit: kg/capita/day	SDG 11.6.1
3	Municipal solid waste composition	3.1 - 3.6	Composition of the total MSW generated within the case study. Check Section B1 for further details.  Unit: weight-%	See Section B1
4	Amounts per material diverted from disposal for recovery	5.1 – 5.6 6.1 – 6.6 7.1 – 7.6	Approximate amounts per material type that are diverted for any recovery option including energy recovery.  Unit: Tonnes/day	SDG 11.6.1
5	Split between the formal and informal collection for recovery	6.1 – 6.6 7.1 - 7.6	For each material type collected for recovery (i.e. sorted), the %-share sorted by the informal sector should be estimated.  Unit: % of total material X recovered	See Section B2
6	Rejects from formal and informal sorting facilities	12.1 & 13.1	Approximate %-share of incoming material that is rejected.  Unit: % of formally / informally collected plastic	See Section B3
7	Waste collected by the informal service-chain	8.2	This data point assess how active the informal service chain are in the study area. For this the informal collection	See Section B4



			<p>services are compared to the formal collection services, with population covered by each an appropriate proxy to use to establish amounts of waste collected by each. This data point is further used in the WFD model to estimate how much of the waste collected by the informal sector for recovery derived from the informal service chain compared to the informal value chain. This is done by applying a normalisation procedure, as explained in Section B3.</p> <p>Unit: % of waste collected by informal service-chain compared to all service-chain</p>	
<b>8</b>	Amounts of materials going to disposal facilities	4.1 – 4.6	<p>Total amount of disposed MSW in all disposal facilities within the case study.</p> <p>Unit: Tonnes/day</p>	SDG 11.6.1
<b>9</b>	Composition of disposed waste at disposal facilities	4.1 – 4.6	<p>Composition of the MSW disposed, which was generated within the case study.</p> <p>Unit: % of each material over total</p>	SDG 11.6.1
<b>10</b>	Materials extracted from disposal facilities	NA	<p>These represents amounts per material collected from disposal facilities by informal value chain.</p> <p>Recyclables extracted from the disposal facilities are accounted twice as amounts disposed in and also as amounts recovered. Consequently, they need to be subtracted to the disposed amounts in order to avoid double counting.</p> <p>Unit: Tonnes/day</p>	SDG 11.6.1
<b>11</b>	Level of control of sorting and disposal facilities	9.1 – 9.3	<p>The level of control of the sorting and disposal facilities can be evaluated in order to complete the SDG 11.6.1 assessment. Not required for the plastic leakage assessment.</p>	SDG 11.6.1

From all data points required, three are not covered in the SDG 11.6.1 methodology and are instead explained below:

**B1: Data point 3 – Municipal solid waste composition**

This section explains the data requirements and steps to calculate the composition of the total generated MSW. This method is particularly recommended for cities whose SW data was obtained through the SDG 11.6.1 assessment. This assessment measures the composition of household waste and disposed waste. However, it does not measure the composition of the total generated MSW.

As explained in the definition chapter, MSW consists not only of household, but also of commercial and institutional waste (CIW). The SDG 11.6.1 assessment does not measure composition of CIW (i.e. non-household MSW waste). Consequently, an additional calculation step is required when calculating the composition of the total generated MSW. This is explained here. Below we listed the information required. All these parameters can be obtained through the SDG 11.6.1 assessment:

- Total population
- Household generation per capita
- Household composition data
- Total recovered MSW per material fraction
- Total disposed MSW amount
- Composition of MSW disposed
- Amounts extracted from disposal sites per material fraction (if available)

In the coming lines, the steps to calculate the composition values of total MSW generated are numbered. In all steps we will make reference to Table 5. This table gathers all information required for the calculation.

- 1. Obtain recovered amounts per fraction:**
  - a. The required data points are obtained as explained in Step 4 of the SDG 11.6.1 assessment.
  - b. Insert the values in Line 1 of Table 5.
- 2. Calculate disposed amounts per fraction:**
  - a. This is calculated using the formula below.
  - b. The total waste disposed is obtained as explained in Step 5 of the SDG 11.6.1 assessment.
  - c. The composition of disposed waste is obtained as explained in Step 6 of the SDG 11.6.1 assessment. If trucks coming from different income neighbourhoods were used for the measurement, use the composition values of the income level with the highest population share, or make an average.
  - d. Insert the values in Line 2 of Table 5.



**3. Calculate uncollected MSW amount:**

a. This is calculated using the formula below.

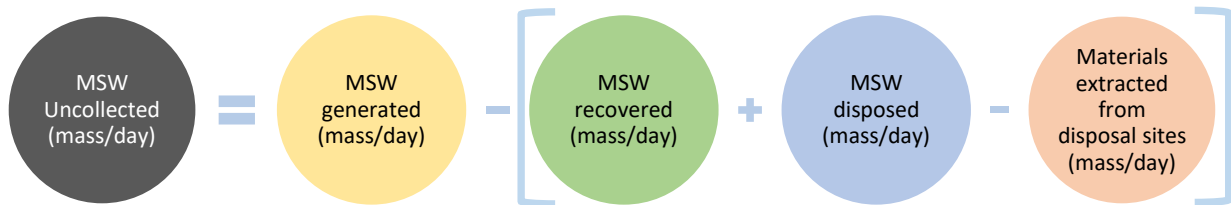

b. Total generated MSW amount (t/year). This calculated using the formula below.

c. When the non-household MSW (i.e. CIW) is unknown, the following proxy can be used: CIW represents 30% of the total MSW generated.

d. The WFD tool calculates this automatically. This figure can be found in the “Results summary” sheet.

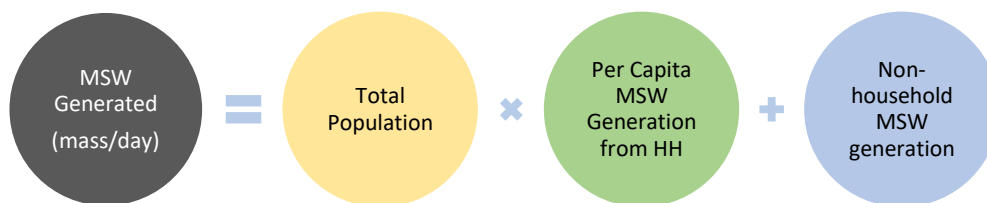

**4. Calculate uncollected amounts per fraction:**

a. This is calculated using the formula below.

b. Use household waste composition data, which is obtained as explained in Step 2 of the SDG 11.6.1 assessment.

c. Insert the values in Line 3 of Table 5.



**5. Obtain amounts extracted from disposal sites per fraction:**

a. If available, obtain this information as explained in Step 5 of the SDG 11.6.1 assessment.

b. Insert these values in Line 4 of Table 5.

**6. Sum up total amounts per fraction:**

a. Calculate total amounts per fraction using the formulas fill in Line 5 of Table 5.

**7. Calculate composition values of total MSW:**

a. Calculate the composition values using the formulas shown in Line 6 of Table 5.

In order to obtain the MSW composition, the following data is required.

**Table 5: Data requirements and method to calculate MSW composition from SDG 11.6.1 assessment data.**

	Paper/card.	Plastics	Glass	Metal	Other	Organic	Total
<b>1 MSW recovered (mass/day)</b>	$PC_D$	$P_D$	$G_D$	$M_D$	$O_{tD}$	$O_D$	$T_D$
<b>2 MSW disposed (mass/day)</b>	$PC_R$	$P_R$	$G_R$	$M_R$	$O_{tR}$	$O_R$	$T_R$
<b>3 MSW Uncollected (mass/day)</b>	$PC_U$	$P_U$	$G_U$	$M_U$	$O_{tU}$	$O_U$	$T_U$
<b>4 Extracted from disposal sites (if available)</b>	$PC_{ED}$	$P_{ED}$	$G_{ED}$	$M_{ED}$	$O_{tED}$	$O_{ED}$	$T_{ED}$
<b>5 Total MSW</b>	$PC_T = PC_D + PC_R + PC_U - PC_{ED}$	$P_T = P_D + P_R + P_U - P_{ED}$	$G_T = G_D + G_R + G_U - G_{ED}$	$M_T = M_D + M_R + M_U - M_{ED}$	$O_{tT} = O_{tD} + O_{tR} + O_{tU} - O_{tED}$	$O_T = O_D + O_R + O_U - O_{ED}$	$T_T = T_D + T_R + T_U - T_{ED}$
<b>6 MSW Composition</b>	$(PC_T / T_T) \cdot 100$	$(P_T / T_T) \cdot 100$	$(G_T / T_T) \cdot 100$	$(M_T / T_T) \cdot 100$	$(O_{tT} / T_T) \cdot 100$	$(O_T / T_T) \cdot 100$	100%

## **B2: Data point 5 - Split between the formal and informal collection of recyclables**

The methodology for SDG 11.6.1 involves conducting detailed interviews with recovery companies. The data on how much of the materials originate from the formal or informal sector should at best be obtained at this stage. Please make sure you interview the biggest players per material according to the instructions given in SDG 11.6.1.

Most recovery facilities know who supplies them with materials. Often they can even tell how much of the materials originate from suppliers who are supplied by the informal sector. When interviewing them, ask them to give an approximate percentage on how much of each material process has its origins in the informal sector. Based on that percentage, you can then calculate the mass flows for each origin by combining with data point 4, and insert these calculated values into the model.

If it is not possible to obtain the data as outlined above, there are two alternative options:

- 1) Assign an expert guess percentage (preferred option); or
- 2) Assign 100% of the materials sorted for recovery to either the formal or informal sector.

Choosing the second option would have some important consequences: The other sector's contribution to the value chain would be entirely disregarded. All the leakages would be assigned to that sector limiting the tool's ability to inform future mitigation measures.

## **B3: Data point 6 - Rejects from formal and informal sorting facilities**

To determine the plastic leakage from sorting facilities, you should understand how much rejects are generated and how they are subsequently dealt with. The model considers two such leakage flows: one for informal sorting facilities and another for formal facilities.

The first step is to identify the formal and informal sorting facilities within the case study. This forms part of the interview stage as described in the preceding section. In case studies with a low level of complexity, this might be quite straightforward, however, in big cities, this can be more complicated. In the latter case, you should include a few additional steps to the SDG 11.6.1 methodology. The WFD aims at the very first level of sorting that occurs before those materials reach recovery facilities. However, the SDG 11.6.1 assessment only looks at these recovery facilities, which represent the last step of the value chain present within the system boundaries of the case study. These are normally recycling or exporting facilities. When following the SDG 11.6.1 and interviewing the recovery facilities, you will have to add the following steps when looking at the value chain:

- **Identify suppliers of the recovery facilities:** During the interviews with the big recovery facilities, try to identify who supplies them with the materials. Note the name of the main suppliers, their telephone numbers, and whether they operate as a formal or informal entity.
- **Make contact with a selected few:** You will notice that the closer you go to the source of the materials, the more players involved. We recommend you call or visit a select few that best represent the overall market.
- **Obtain the percent share of rejects and their destination:** Either during the telephone calls or visits, you should obtain two pieces of information:
  - 1) The percent share of rejects generated in contrast to the amounts they process;
  - 2) The facility's management of rejects.
- **Calculate the average.** Obtain an average share of rejects for each kind of facility based on the sorting facilities visited or called. You may obtain a different value for the formal and informal facilities.

#### **B4: Data point 7 - Collection by informal service-chain compared to formal collection services**

This data point assesses the amount of material collected by the formal service chain compared to the informal service chain. As this may be difficult to obtain, the WFD recommends the use of a proxy: the percentage of population served by an informal waste collection services compared to formal collection services. This percentage can be estimated by assessing where the informal and formal waste collection services are operating. If local officers report not to be covering parts of the city (i.e. informal settlements), the user should visit these areas and observe how waste is being collected there. Conduct minor interviews to find out if any community based organisations (CBO) or any other collection service is operating informally. If that is the case, estimate the percentage of population living in the area and use it for this data point. If there is no such informal waste collection services, then your data entry would be zero.

The WFD uses this information to estimate how much of the waste collected by the informal sector for recovery (F9) came from the informal service-chain compared to the informal value-chain. It does this by normalising the entered value to a maximum of 80% so as to account for the fact that the informal value chain are always present alongside the service chain, no matter how strong the informal service chain is. For example, if you enter that 100% of the MSW collection is performed by the informal service chain, this would assign 80% of the waste collected by the informal sector for recovery (F9) to the informal service chain and the remaining 20% to the informal value chain. Likewise, if you enter that 50% of the collection services are performed by the informal service-chain, this would calculate that 40% of the waste collected by the informal sector for recovery would come from the informal-service chain, and the remaining from the informal value chain.



## Step C: Quantifying plastic leakage

Once the information of the MSWM system is compiled, the next step is to quantify the plastic waste leaking out of each stage of the MSWM system into the environment. The methodology behind this quantification is as follows:

- 1) **MSWM stages:** A MSWM system is composed of different stages, namely: waste generation, collection, sorting, transportation and disposal. In every one of these stages, plastic can leak into the environment. In the case of the generators, this plastic leakage is counted as uncollected by the WFD.
- 2) **Leakage influencers:** For each stage, the WFD considers a set of aspects or leakage influencers related to infrastructure and practices that influence the potential leakage of plastic from that stage. Every stage of the MSWM has several leakage influencers, usually between 3 and 5.
- 3) **Leakage potential levels:** Each leakage influencer has different levels of leakage potential: none, low, medium, high or very high.
- 4) **Leakage factors:** Every leakage potential level is accompanied with a leakage factor. The leakage factors are expert-guessed factors representing the percentage share of plastics at that particular stage of the MSWM system that (could) leak into the environment. Descriptive tables are provided in this section of the user manual for each stage of the MSWM system and for each leakage influencer. The user must conduct observation-based assessments to determine which description matches best with the on-the-ground infrastructure and waste management practices.
- 5) **Leakage decision trees:** For convenience, all leakage influencers, their different leakage potentials and corresponding leakage factors, are arranged in decision trees. There is one decision tree for each stage of the MSWM system.
- 6) **Combined leakage percentage:** Each decision tree also contains a formula which shows how the leakage factors assigned to each leakage influencer are combined in order to calculate the combined leakage percentage. The way these leakage factors are combined depends on their inter-dependency. Factors which belong to dependent influencers will be multiplied, whereas leakage factors from independent influencers will be summed.
- 7) **Plastic leakage:** The WFD calculates the total mass of plastic leaking from each stage of the MSWM system by multiplied the combined leakage percentages by the total amount of plastic moving through that stage.
- 8) **Total plastic leakage:** The total plastic leakage represents the sum of the plastic leakages from all MSWM system stages. Combined with the uncollected waste gives the unmanaged waste.
- 9) **Total plastic leakage to land/drain/burnt/water:** The fates of the plastic leakage are then determined as discussed in Step D.

In this chapter we will cover every stage of the MSWM system individually, where the leakage influencers, their leakage potential levels and associated descriptions and leakage factors will be described. An example of assessing leakage influencers for the case of transportation is given in Annex 2, whilst an example for disposal sites is explained in the accompanying online training package.

**Note:** The leakage influencers list infrastructure and practices for each process which impact the amount of plastic emitted to the environment. Please read the descriptions and select the one which best describes the waste management in your city. However, within a case study such as a large city, the infrastructure and practices used often vary considerably. In this case, the user should choose a description which best matches the **average** situation within their city.

### **C1: Plastic leakage from collection services**

Leakage of plastic from collection services (F12) refers to the plastic which escapes the waste management system whilst:

- 1) It is being stored waiting for collection services;
- 2) It is being loaded on to the collection vehicle;
- 3) It is on primary transportation.

Waste collection is typically the most expensive aspect of MSWM, largely due to the need to regularly collect waste from lots of disperse points across the municipality. This typically begins with residents and businesses having to dispose of their waste in collection containers, from which the collection service can collect from. The more collection containers present, the easier it is for residents to dispose of their waste, yet this also increases time and cost for the collection services. Due to the widespread nature of operations and associated expense, waste collection infrastructure and practices often vary considerably. Without significant investment, much of this infrastructure is likely to suffer from having inadequate levels of waste containment, dilapidation over time, as well as potential misuse by residents.

Additionally, the collection of the waste requires the collection services to load the stored waste onto transportation vehicles. Depending on the infrastructure involved this may be a manual task or largely automated. The waste may also have to go through a series of aggregation stages to get it to a sufficient quantity for transportation to treatment and disposal. These first collection and aggregation stages are known as primary transportation, whereas the subsequent transfer to treatment and disposal is secondary transportation. Although this repeated transfer and aggregation of waste may make sense practically, the repeat movement and multiple handling of the waste can also impact the amount of plastic that can escape into the environment.

Considering the above, waste collection is often believed to contribute large amounts to unmanaged plastic in the environment. Although these leakages from collection services are often small in comparison to the total volume of waste being collected, the widespread nature of collection means these leakages have the potential to add up to significant numbers.

The decision tree for the collection services, presenting all leakage influencers, their leakage potential levels and corresponding leakage factors is shown in Figure 9. Likewise, the descriptive table on which the observation assessments should be based are shown in Table 6 -Table 9.

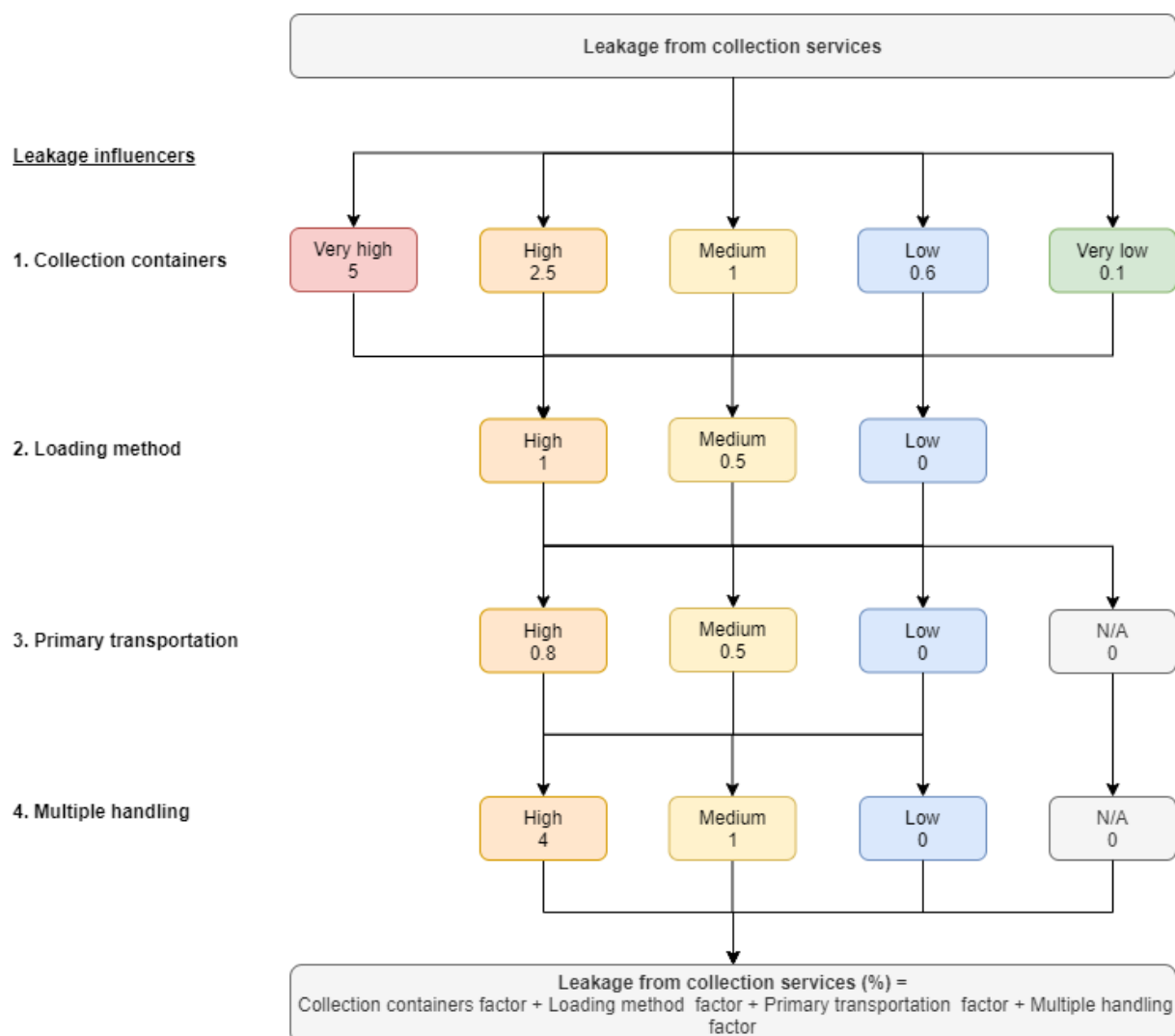

**Figure 9: Decision tree and leakage calculations for collection services**

*Collection containers*

**Table 6: Leakage potential levels for influencer “collection containers”**

Leakage potential	Description	Leakage factor
<b>Very high</b>	Most of the waste is openly stored outside without any dedicated container (e.g. temporary disposal sites). Frequency of collection is very low compared to what is required. Service is very often delayed beyond the minimum frequency. Most waste is disposed of loose.	5
<b>High</b>	Containers are available in most but not all districts but they are open to the environment (no lids / gaps in side), shows high levels of damage, and/or are readily accessible by animals. The capacity of the bins may be insufficient for the quantity of waste or difficult to access therefore dumping waste around the collection container is typical. Frequency of collection is low compared to what is required. Service is often delayed beyond the minimum frequency. Small amounts of waste are disposed of in bags.	2.5
<b>Medium</b>	Containers are available in most but not all districts. The storage containers are open to the environment (no lids / gaps in side), show low levels of damage, and are not easily accessible by animals. The capacity	1

	of the bins is generally sufficient for the quantity of waste but some dumping of waste around the collection container may occur. Frequency of collection is slightly below what is required. Service is occasionally delayed beyond the minimum frequency. Waste is occasionally disposed of in bags.	
<b>Low</b>	Containers are available in all districts but are typically open to the environment (no lids / gaps in side), show low levels of damage, and are not easily accessible by animals. The capacity of the bins is generally sufficient for the quantity of waste but some dumping of waste around the collection container may occur in small quantities. Frequency of collection is adequate for what is required. Service is very occasionally delayed beyond the minimum frequency. Waste is commonly disposed of in bags.	0.6
<b>Very low</b>	Containers are available in all districts with them closed to the environment (lids and fully enclosed sides), show low levels of damage, and are not easily accessible by animals. The capacity of the bins is sufficient for the quantity of waste with little to no waste dumped around the collection container. Alternatively, waste is kept indoors prior to formal collection. Frequency of collection is adequate what is required. Service is rarely beyond the minimum frequency. Waste is predominately disposed of in bags.	0.1

#### *Loading method*

**Table 7: Leakage potential levels for influencer “loading method”**

<b>Leakage potential</b>	<b>Description</b>	<b>Leakage factor</b>
<b>High</b>	Most of the waste must be manually loaded to vehicles with shovels / wheelbarrows / heavy machinery. Waste is transferred to the collection vehicle from a fixed collection container / location.	1
<b>Medium</b>	Most of the waste must be manually loaded to vehicles however the storage containers are generally portable and are transported to the waste collection vehicle with the waste still inside.	0.5
<b>Low</b>	Most of the waste is loaded using automatic systems. The storage containers are portable and are transported to the waste collection vehicle with waste still inside.	0

#### *Primary transportation*

**Table 8: Leakage potential levels for influencer “primary transportation”**

<b>Leakage potential</b>	<b>Description</b>	<b>Leakage factor</b>
<b>High</b>	The majority of primary transportation vehicles have a small capacity (<5m <sup>3</sup> ) and typically run over capacity. The vehicles container is open to the environment (no cover / gaps in side) allowing waste to easily escape. The vehicle is powered by low-tech options such as human / animal power, or small engines (i.e. motorbikes). Sorting may occur within the transportation vehicle.	0.8
<b>Medium</b>	The majority of primary transportation vehicle have a mid to large capacity (>5m <sup>3</sup> ) but may occasionally run over capacity. The vehicles container is typically open to the environment (no cover / gaps in side) allowing waste to easily escape. Sorting may occur within the transportation vehicle.	0.5

<b>Low</b>	All primary transportation vehicles are closed to the environment (i.e. covered), stays within its capacity limit and may contain advanced features such as compaction mechanisms.	0
<b>N/A*</b>	There is no distinction between primary and secondary collection (i.e. collected waste is immediately transferred to disposal)	0

\* If immediately transferred to disposal, leakages during transportation are calculated in the transportation decision tree.

### Multiple handling

**Table 9: Leakage potential levels for influencer “multiple handling”**

<b>Leakage potential</b>	<b>Description</b>	<b>Leakage factor</b>
<b>High</b>	Collected waste is transferred between multiple vehicles / people with low frequency between transfers (i.e. long wait times). There is no dedicated facility for the transfer of waste with this generally occurring on the side of streets. Waste containment during transfer is poor, typically being loaded onto the ground prior to loading the secondary transportation vehicle. Poor / non-existent site management.	4
<b>Medium</b>	Collected waste is transferred between multiple vehicles / people with a typically short frequency between transfers. There are dedicated facilities for the transfer of waste although waste containment during transfer is poor, typically being loaded onto the ground prior to loading the secondary transportation vehicle. Site management is generally adequate.	1
<b>Low</b>	Collected waste is adequately transferred between multiple vehicles / people. There are dedicated facilities for the transfer of waste with high levels of waste containment. Waste is transferred either directly into secondary transportation vehicles, or stored in designated compartments. Site management is good.	0
<b>N/A*</b>	There is no distinction between primary and secondary collection (i.e. collected waste is immediately transferred to disposal)	0

\* If immediately transferred to disposal, leakages during transportation are calculated in the transportation decision tree.

## C2: Plastic leakage from informal value-chain collection

Plastic leakages during informal value-chain collection (F13) refer to the plastic waste which escapes the waste management system whilst:

- 1) It is being collected by the value chain of the informal sector;
- 2) It is being transported by the informal sector.

The informal waste sector is active in many areas of the world. While the service-chain of the informal sector is covered by flow F2 (collection services), the flow here refers to the value-chain of the informal sector. This relates to unregistered and unlicensed individuals or cooperatives that collect waste material which has value for them to subsequently sell.

Collection can be performed by going door-to-door, or from scavenging from litter, collection points, transfer stations or dumpsites. In some cases, the informal sector value-chain can improve plastic leakages by collecting plastic already in the environment, whilst in other cases, they may interfere with infrastructure causing the release of more plastic (i.e. from overturning bins). Within the WFD, the positive effect is accounted for by subtracting that value off the uncollected waste, thereby reducing leakage.

Following the collection, the informal sector workers typically have to transport the material to a location for sorting or sale of the material. This transportation may involve the waste being poorly

contained and as such to the leakage of plastic. The decision tree and accompanying descriptive table on which the observation assessments should be based are shown in Figure 10 and Table 10 - Table 11 respectively.

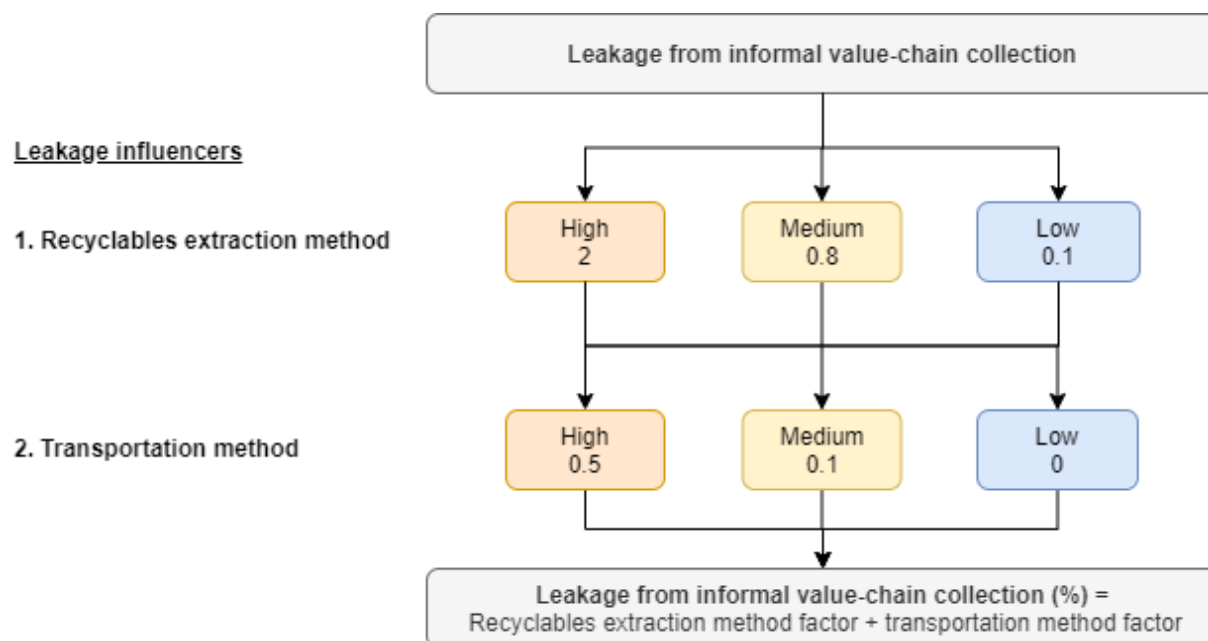

Figure 10: Decision tree and leakage calculations for informal value-chain collection.

#### Recyclables extraction method

Table 10: Leakage potential levels for influencer “extraction method of recyclables”

Leakage potential	Description	Leakage factor
High	The informal sector is seen to cause significant release of waste into the environment during collection in most of the city. Practises such as overturning bins to get access to valuable material and discarding unwanted items during the collection (bottle tops, labels etc.) is common.	2
Medium	The informal sector is seen to cause moderate release of waste into the environment during collection. Practises such as overturning bins to get access to valuable material and discarding unwanted items during the collection (bottle tops, labels etc.) occurs occasionally.	0.8
Low	Most of the plastic materials are separately collected from the source. The informal sector is seen to cause little to no release of waste into the environment during collection. Practises such as overturning bins to get access to valuable material and discarding unwanted items during the collection (bottle tops, labels etc.) are rare.	0.1

#### Transportation method

Table 11: Leakage potential levels for influencer “transportation method”

Leakage potential	Description	Leakage factor
High	The plastic waste transported is predominantly poorly contained (not in bags). Most vehicles run over capacity	0.5



<b>Medium</b>	The plastic waste transported is occasionally poorly contained. Over capacity of vehicles leading to leakages during transportation is intermittent.	0.1
<b>Low</b>	Most vehicles used to transport plastic waste are closed to the environment (i.e. cover). Most vehicles stay within their capacity limit	0

### C3: Plastic leakage from formal sorting

Formal sorting facilities a wide range of potential technologies and processes. Depending on their purpose a combination of different stages or processes can be applied, including further processing of separated materials to increase their quality and market value. However, formal sorting facilities also handle substantial quantities of waste that unsuitable for recycling. These rejects have to be disposed of by the sorting facility, which if mismanaged can lead to large release of plastic to the environment. Whilst, some plastic may also leak from the sorting facility due to wind or surface-runoff, these are believed to be negligible in comparison and therefore excluded from this analysis. Leakage of plastic from formal sorting facilities (F14) therefore considers the disposal practices of plastic rejects from the sorting process as shown in the decision tree in Figure 11. A descriptive table to describe the management of the rejects is included in Table 12.

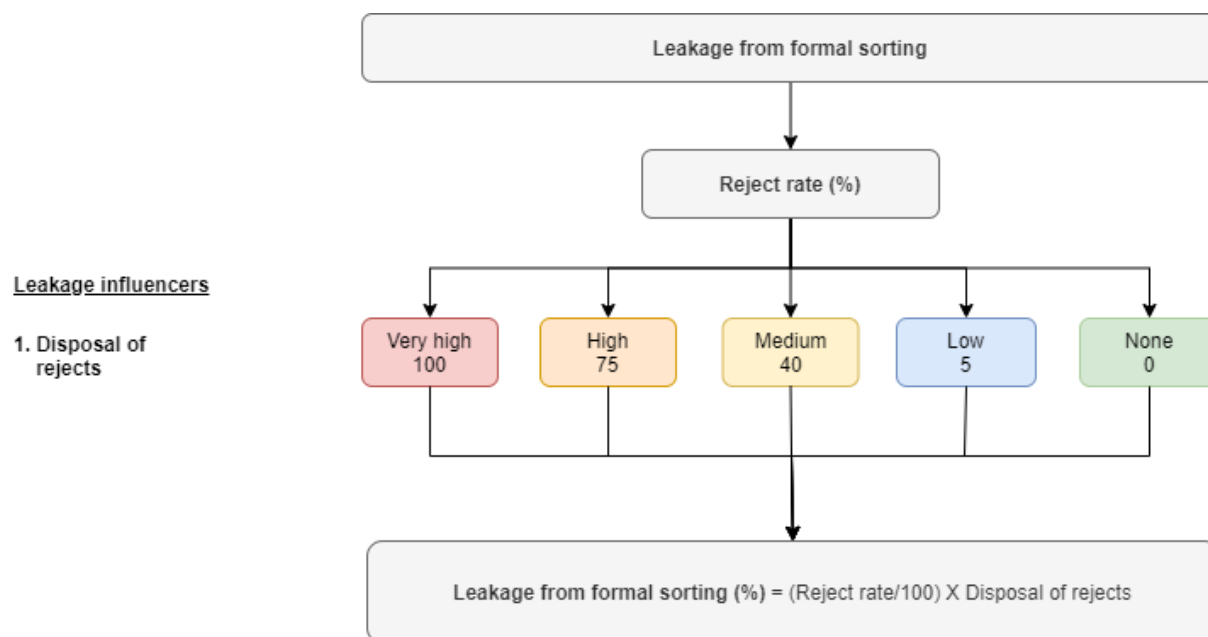

Figure 11: Decision tree and calculation of leakages from the formal sorting facilities

#### Formal disposal of rejects

Table 12: Leakage potential levels for influencer “Formal disposal of rejects

Leakage potential	Description.	Leakage factor
<b>Very high</b>	None of the sorting facilities dispose of sorting rejects in the formal collection system. There is a complete absence of formal services. Frequent dumping or open burning of rejects is widespread.	100
<b>High</b>	A minority of sorting facilities dispose of the sorting rejects to the formal collection system. There are occasional formal containers or drop-off points in the area. Dumping or open burning of rejects is known to occur frequently.	75

<b>Medium</b>	A significant amount of the sorting rejects are returned to the formal system, however some dumping or open burning of rejects is known to occur in areas.	40
<b>Low</b>	Most of the sorting rejects are returned to the formal system, containers or depots in the vicinity are regularly serviced and the area is linked to a formal system. Most dumping or open burning of waste is not believed to have originated from the sorting activities.	5
<b>None</b>	All of the sorting rejects are returned to the formal system, containers or depots in the vicinity are regularly serviced and the area is linked to a formal system. Any dumping or open burning of waste is not believed to have originated from the sorting activities.	0

#### **C4: Plastic leakage from informal service-chain sorting**

Informal sector activities are mainly geared towards separating and processing valuable recyclables from the waste streams. Such facilities aim at obtaining a most efficient amount of valuable materials as dictated by the recyclable markets, so sorting and processing can be very selective. They are largely based on manual labour but can have quite sophisticated equipment for sorting, shredding, extruding or other mechanical processes. These facilities might potentially generate significant amounts of residues which can be either returned to the formal system or disposed of in an uncontrolled way. As with the formal sorting facilities, this disposal of the rejects is believed to dominate the plastic leakage, and therefore any leakage due to wind or surface-runoff is assumed negligible and omitted from the analysis.

Leakage of plastic from informal service-chain sorting (F15) therefore is related to rejected plastics which might be dumped or mismanaged. The decision tree and accompanying descriptive table on which the observation assessments should be based are shown in Figure 12 and Table 13 respectively.

**Note:** Plastic leakage from informal service-chain sorting is only applied to the service-chain branch of the informal sector. As such, the value-chain is omitted from this. This is due to the first stage of sorting (as measured by the WFD) for the value-chain is at the point of collection. For example, waste pickers collecting valuable materials are automatically sorting waste as they pick by not collecting low-value items. Any leakages associated with this are instead assigned to the collection phase (see Step C1).

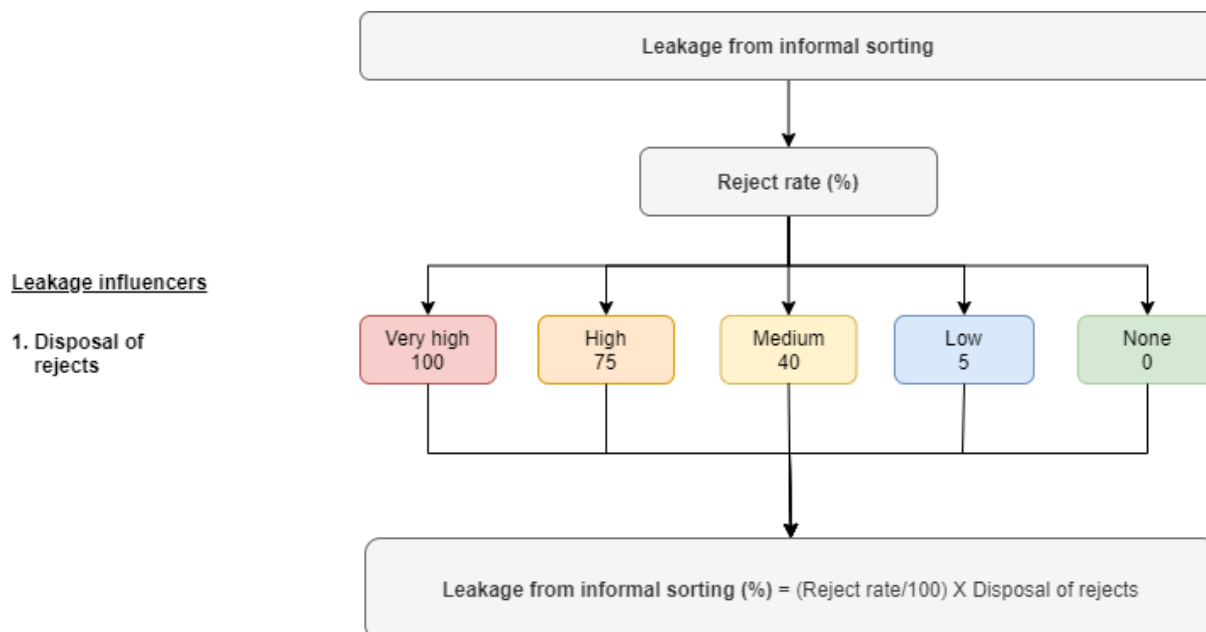

**Figure 12: Decision tree and calculation of leakages from the informal sorting facilities**

*Formal disposal of rejects*

**Table 13: Leakage potential levels for influencer “formal disposal of rejects”**

Leakage potential	Description.	Leakage factor
<b>Very high</b>	None of the sorting facilities dispose of sorting rejects in the formal collection system. There is a complete absence of formal services. Frequent dumping or open burning of rejects is widespread.	100
<b>High</b>	A minority of sorting facilities dispose of the sorting rejects to the formal collection system. There are occasional formal containers or drop-off points in the area. Dumping or open burning of rejects is known to occur frequently.	75
<b>Medium</b>	A significant amount of the sorting rejects are returned to the formal system, however some dumping or open burning of rejects is known to occur in areas.	40
<b>Low</b>	Most of the sorting rejects are returned to the formal system, containers or depots in the vicinity are regularly serviced and the area is linked to a formal system. Most dumping or open burning of waste is not believed to have originated from the sorting activities.	5
<b>None</b>	All of the sorting rejects are returned to the formal system, containers or depots in the vicinity are regularly serviced and the area is linked to a formal system. Any dumping or open burning of waste is not believed to have originated from the sorting activities.	0

**C5: Plastic leakage during transportation to disposal**

Plastic leakage during transportation to disposal (F16) refers to the plastic items lost when the material is being transported by the collection vehicles to its final destination. This indicator only considers the amounts of plastic leaked during the action of transportation.

Often, collection services are split into primary and secondary collection. If this is the case, this leakage flow only considers the amounts of plastic lost during transport of the secondary collection vehicles. The leakage from primary collection services is covered by F12 as described in sections C1. If collection

services are not split, this indicator covers all plastic leakage from transportation. This avoids double counting by setting the transportation factors in C1 to zero.

The best way to assess this indicator is to plan an observation campaign in the final destination where the waste is brought (i.e. disposal site, or recovery facilities). Observe the trucks arriving to the sites for a few hours. Evaluate the presence of the reduction measures explained below and assign the appropriate leakage factor.

The decision tree and accompanying descriptive table on which the observation assessments should be based are shown in Figure 13 and Table 14 - Table 16 respectively. An example of the how to assess these influencers is also provided in Annex 2.

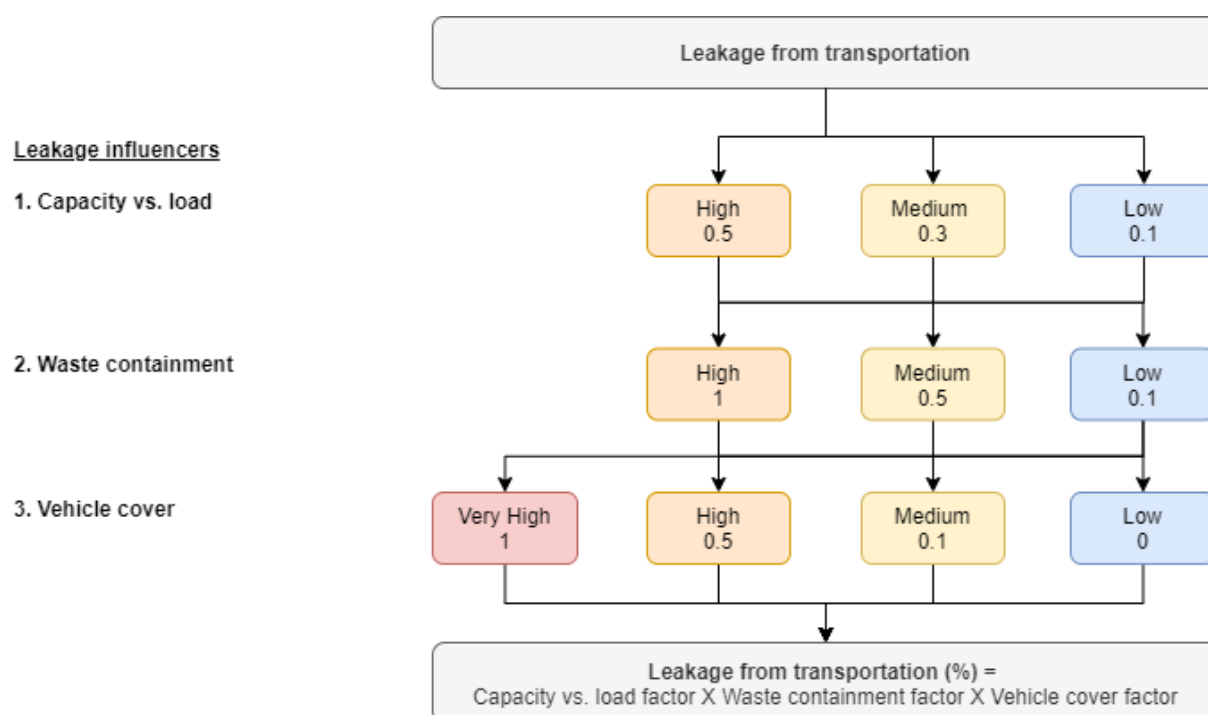

Figure 13: Decision tree and calculation of leakages from Transportation

*Capacity vs load*

Table 14: Leakage potential levels for influencer “Capacity vs load”

Leakage Potential	Description	Leakage Factor
High	The load in most of the collection vehicles exceeds the capacity.	0.5
Medium	Around half of the trucks’ load exceeds the capacity.	0.3
Low	The load in most of the collection vehicles does not exceed the capacity.	0.1

### Waste containment

**Table 15: Leakage potential levels for influencer “Waste containment”**

Leakage Potential	Description	Leakage Factor
High	Most of the generators in the city do not dispose of their waste contained in bags. Loaders practice cherry picking during transport for which they open most of the bags.	1
Medium	Around half of the generators in the city dispose of their waste contained in bags and the other half uncontained. Loaders practice some cherry picking during transport for which they open some of the bags.	0.5
Low	Most of the generators in the city dispose of their waste contained in bags and these are not opened during transport.	0.1

### Coverage of collection vehicle

**Table 16: Leakage potential levels for influencer “Coverage of collection vehicle”**

Leakage Potential	Description	Leakage Factor
Very high	Most of the collection vehicles in the city are uncovered vehicles	1
High	The number of collection vehicles are fairly split between uncovered and fully enclosed.	0.5
Medium	Most of the collection vehicles in the city are fully enclosed.	0.1
Low	All of the collection vehicles in the city are fully enclosed (e.g. compactor trucks)	0

## C6: Plastic leakage from disposal facilities

Leakage of plastic from disposal facilities (F17) refers to plastic that leaks from disposal sites carried either by either the wind (windblown) or by water/landslides.

Windblown leakage is one of many operational concerns in the management of a landfill. In spite of the abundance on guidelines on how to manage and avoid this leakage (Law and Appelqvist, 2019, Martel and Helm, 2004), no quantitative data was found with estimates or measurements of on quantities.

You will notice that the two separate plastic leakage types (wind and water/landslides) are separated in the decision tree. In some sites you might find just one, whilst in others, both types of leakage might be present. The combined leakage is the sum of both as shown in the formula at the bottom of the decision tree (Figure 14). Accompanying this decision tree are the descriptive table on which the observation assessments should be based (Table 17 - Table 22).

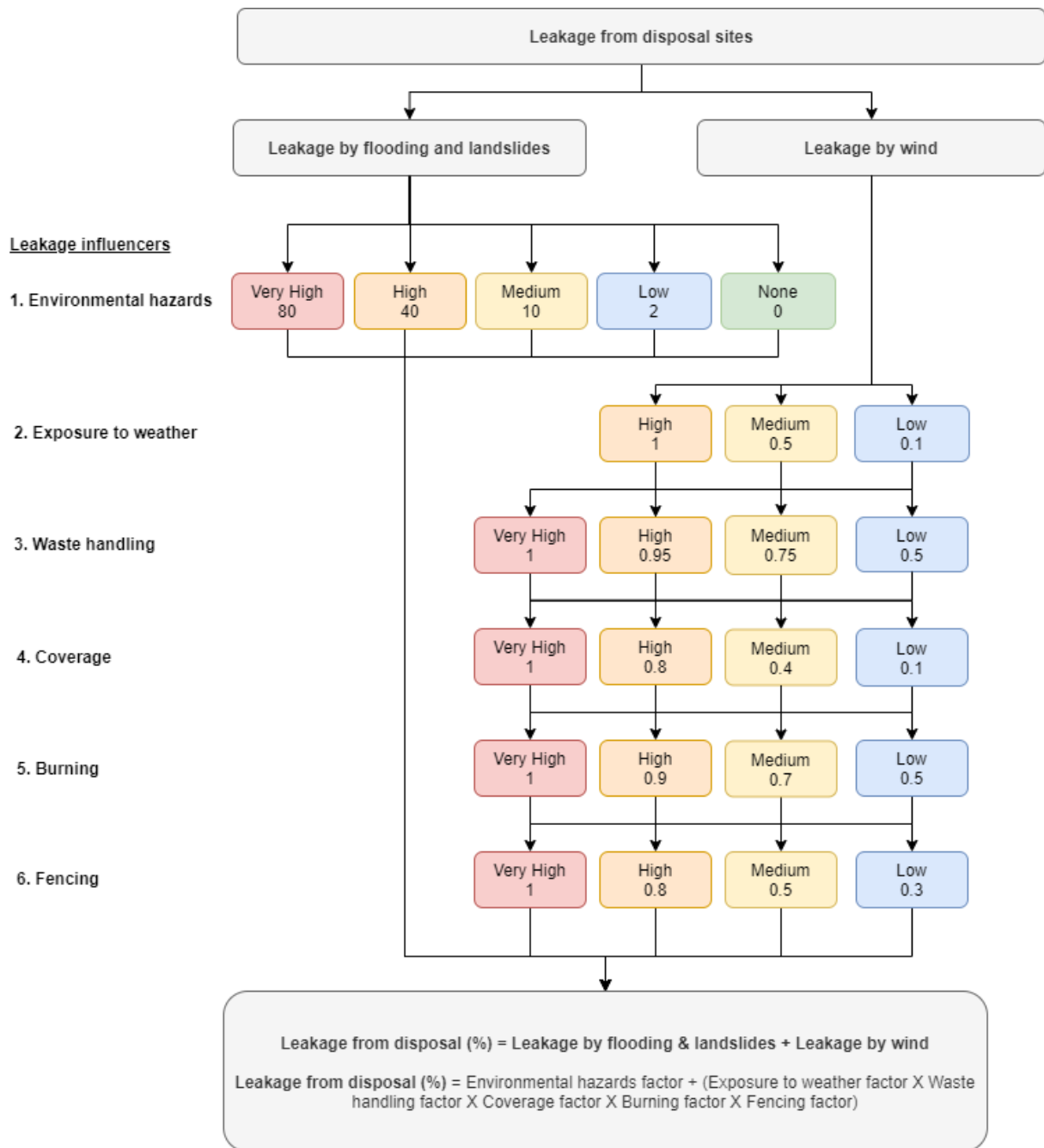

**Figure 14: Decision tree and calculation of leakages from disposal facilities**

*Environmental hazards*

**Table 17: Leakage potential levels for influencer “environmental hazards”**

Leakage Potential	Description	Leakage Factor
<b>Very High</b>	Site is located in an area prone to regular flooding or landslides affecting the majority of the site.	80
<b>High</b>	Site is located in an area prone to occasional flooding or landslides affecting large parts of the site.	40
<b>Medium</b>	Site is located in an area where regular flooding or landslides affect small parts of the site.	10



<b>Low</b>	Site is located in an area where regular flooding or landslides affect very few parts of the site.	2
<b>None</b>	Site is located in an area which does not regularly have environmental hazards such as flooding or landslides	0

\*Regularly refers to what repeatedly happens each year. Extreme / rare events are not considered here.

#### *Exposure to weather*

**Table 18: Leakage potential levels for influencer “exposure to weather”**

<b>Leakage Potential</b>	<b>Description</b>	<b>Leakage Factor</b>
<b>High</b>	Site is regularly exposed to heavy and persistent winds or surface runoff.	1
<b>Medium</b>	Site is sometimes exposed to heavy and persistent winds or surface runoff.	0.5
<b>Low</b>	Site is rarely exposed to heavy and persistent winds or surface runoff.	0.1

#### *Waste handling*

**Table 19: Leakage potential levels for influencer “waste handling”**

<b>Leakage Potential</b>	<b>Description</b>	<b>Leakage Factor</b>
<b>Very High</b>	No designated discharge zones. Waste pickers active on all the site. No compaction or management of waste. Waste is piled above ground with full exposure to wind, rain and surface runoff.	1
<b>High</b>	Waste is generally discharged in designated zones. Waste pickers active on most of the site. Compaction or management of waste typically does not occur. Waste is piled above ground with full exposure to wind, rain and surface runoff.	0.95
<b>Medium</b>	Waste is generally discharged in designated zones. Waste pickers active around discharge zone of the site. Compaction or management of waste is intermittent. Waste is piled above ground with full exposure to wind, rain and surface runoff.	0.75
<b>Low</b>	Waste is discharged in designated zones. Waste pickers are not allowed on site. Compaction or management of waste occurs. Waste is in pits below ground level with minimal exposure to wind, rain and surface runoff.	0.5

#### *Coverage*

**Table 20: Leakage potential levels for influencer “coverage”**

<b>Leakage Potential</b>	<b>Description</b>	<b>Leakage Factor</b>
<b>Very High</b>	No coverage or covered less than once per month	1
<b>High</b>	Waste is covered typically once per month	0.8
<b>Medium</b>	Waste is covered typically once per week	0.4
<b>Low</b>	Waste is covered typically daily	0.1

### Burning

**Table 21: Leakage potential levels for influencer “Burning”**

Leakage Potential	Description	Leakage Factor
Very High	Burning of waste does not occur	1
High	Burning of waste is rare	0.9
Medium	Burning of waste is occasional	0.7
Low	Burning of waste is widespread and prevalent	0.5

### Fencing

**Table 22: Leakage potential levels for influencer “Fencing”**

Leakage Potential	Description	Leakage Factor
Very High	No fencing	1
High	Fence surrounds less than half of the perimeter or big sections of the fence are broken	0.8
Medium	Fence surrounds most of the perimeter but is broken in several sections	0.5
Low	Fence surrounds the entire perimeter and is maintained	0.3

## C7: Plastic in storm drains to water systems

This section represents the amount of plastic which is transferred through storm drain systems and enters water systems. In most cities, there is little information available on solid waste washed into drainage systems and the methods or quantity / quality of removed solid waste. However, often the solid waste washed into drainage systems is ‘sooner or later’ completely washed out into water systems such as rivers. This especially applies for open and uncontrolled drainage systems. The exception to this is where drain cleaning occurs. Many countries periodically clean storm drains so as to avoid flooding issues associated with the build-up of waste to the point whereby it blocks the flow of water. These cleaning events may be regular, or be targeted to occur before the onset of heavy rain events such as the rainy season.

The logic used for the calculation of how much plastic in storm drains reaches waterbodies is based on the following concept. It assumes that any plastic not removed from the drains by cleaning, is eventually transferred to waterbodies. As rainfall dictates when this plastic will become mobile within the drains, the more frequent the rainfall, the less opportunity there is to remove the waste before it gets washed into waterbodies. In contrast, the more frequent and widespread the drain cleaning, the less waste there will be in the drains to be transferred at the next rainfall event. These competing and dependent factors are related as shown in the decision tree of Figure 15. The associated descriptive tables are outlined in Table 23 - Table 24.

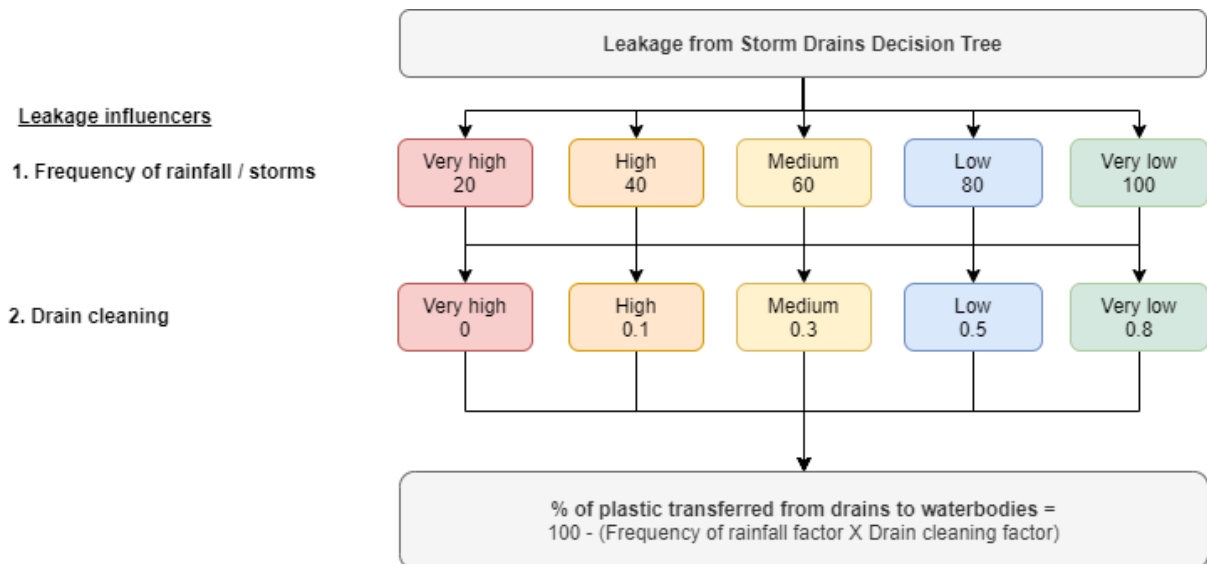

**Figure 15: Decision tree and calculation of storm drain litter removal**

**Table 23: Leakage potential levels for influencer “frequency of rainfall and storm events”**

Leakage Potential	Description	Leakage Factor
<b>Very High</b>	Rainfall and heavy storms are frequent throughout the year with all 12 months having an average precipitation of at least 60 mm. Equivalent of the tropical rainforest climate (Af) in the Köppen climate classification.	20
<b>High</b>	Rainfall is frequent throughout the year with heavy storms often occurring during the hotter months. There is no predictable dry summer month. Equivalent of the humid subtropical climate (Cfa), oceanic climate (Cfb), subpolar oceanic climates (Cfc) or wet continental climates (Df) in the Köppen climate classification.	40
<b>Medium</b>	Rainfall is highly seasonal, often impacted by monsoon rains, with a dry season and wet season. Equivalent of the tropical monsoon (Am), dry-winter subtropical (Cw) or dry-winter continental climates (Dw) in the Köppen climate classification.	60
<b>Low</b>	Rainfall has a pronounced dry season whilst the short wet season has more limited rainfall than above categories. Equivalent of the savannah (Aw), Mediterranean (Cs) or dry-summer continental climates (Ds) in the Köppen climate classification.	80
<b>Very low</b>	Dry climate characterised by little precipitation. Equivalent of the arid (Bw) and semi-arid (Bs) climates in the Köppen climate classification.	100

**Table 24: Leakage potential levels for influencer “drain cleaning”**

Leakage Potential	Description	Leakage Factor
<b>Very High</b>	Storm drains do not have any solid waste cleaning activities. Litter traps are not used.	0
<b>High</b>	A small amount of drains are cleaned once per year. Litter traps are not used.	0.1
<b>Medium</b>	A small amount of drains are cleaned once to twice a year, with this planned to occur before periods of heavy rain (i.e. wet season if	0.3

	applicable). Litter traps are used on a handful of drain outlets and are well maintained.	
<b>Low</b>	A large amount of drains are cleaned once to twice a year, with this planned to occur before periods of heavy rain (i.e. wet season if applicable). Litter traps are used on around half of the drain outlets and are well maintained.	0.5
<b>Very low</b>	The majority of storm drains are cleaned regularly (several times a year). Litter traps are used on the majority of drain outlets and are well maintained.	0.8

## Step D: Determine fates of plastic leakage

Once the amounts for every leakage flow have been determined, the final fates of these plastic flows can be assessed. The WFD tool considers four different fates for the leaked plastic as shown in Table 25.

**Table 25: Definition of the four fates for leaked plastic waste.**

Fate	Includes	Excludes
<b>Burnt</b>	Plastic waste openly burnt as a disposal method (i.e. burning of uncollected waste by residents, or burning of sorting rejects).	Plastic burnt by residents for fuel (as this is not considered as waste), or burning that occurs in dedicated facilities such as incinerators (as this is accounted for by the energy from waste flow).
<b>Land</b>	Plastic waste which remains indefinitely on land. For example, plastic entangled in vegetation, plastic isolated on land with no ability to enter water or drains, and plastic buried by residents. This also includes any plastic waste that originally was on land but has subsequently been collected by street sweeping activities.	Plastic waste at disposal facilities (these are included separately), waste which travels overland and eventually enters water or drains, or waste dumped in pit latrines that is eventually emptied to a location other than land.
<b>Storm drains</b>	Plastic waste removed from storm drains and placed in a location that it will not re-enter at a later stage.	Plastic waste in storm drains which is not removed (as this plastic is assumed to be transported at some point in time to waterbodies if left uncollected), and plastic waste within the sanitary sewer (unless this is combined with the storm drain sewer).
<b>Water systems</b>	Plastic waste which has or will at any point in time enter water systems and remain as such. For definition of what is counted as water systems, see definition in Section 2.	Plastic waste which enters anything not defined as a water system as in the definition given in Section 2.

In order to determine how much of the leaked plastic ends up in each fate, the Waste Flow Diagram follows an observation based methodology. The concept behind this is that users will assess the amount of plastic they see in the environment for each fate, be that on land, in storm drains or remnants from open burning. The exception to this is for water systems. As water systems transport waste away from the site in which it entered, observations cannot give an accurate representation. Instead, the amount of waterbodies and the ability to access them is used as a proxy for potential plastic emissions. These observations will then be linked to the different sources of the initial plastic leakage according to the area they were observed in.

When considering the four fates, the type of leakage will impact the degree to which plastic ends up in each fate. For example, if plastic was to blow off a dumpsite, the burning fate for this flow is not applicable as it escaped involuntarily and is not under anyone's control. In contrast, uncollected waste may be burnt by residents as a disposal option, or alternatively, may be directly dumped to waterways

therefore potentially having a higher probability of enter water systems than waste simply being blown. This is reflected in the WFD by assigning each leakage flow to one of four leakage types.

1. **Voluntary leakage** – waste was purposefully put in the environment (*e.g. dumped / burnt*)
2. **Involuntary leakage** – waste accidentally escaped into the environment (*e.g. wind-blown*)
3. **Diffuse leakage** – Leakage occurs over a large dispersed area (*e.g. collection containers*)
4. **Point source leakage** – Leakage occurs from one of more set locations (*e.g. dumpsites*)

The allocation of these leakage types is summarised for each individual leakage flow in Table 26.

**Table 26: Allocation of leakage flows to fate**

Leakage Flow	Diffuse voluntary	Diffuse involuntary	Point source voluntary	Point source involuntary
Uncollected waste (F4)				
Plastic leakage from collection services (F12)				
Plastic leakage from informal value-chain collection (F13)				
Plastic leakage from formal sorting (F14)				
Plastic leakage from informal service-chain sorting (F15)				
Plastic leakage during transportation to disposal (F16)				
Plastic leakage from disposal facilities (F17)				

Each leakage type and the accompanying descriptions and factors to be used in the observation assessment are discussed in more detail within sections D1 – D4. The observations should be conducted in as many different locations as possible, ideally using a randomised sampling approach, so as to build up a picture of the average prevalence of each fate. For point sources, these observations should occur in the immediate vicinity of the point sources, whilst for diffuse sources this should occur over the entire region of interest. For example, for uncollected waste, observations should be carried out in multiple locations within an area which does not have waste collection, whereas for plastic leaking from collection services, observations should be carried out throughout the area of the city which has collection services.

In circumstances where street sweeping or drain cleaning is active, waste may be entering these fates but be subsequently cleaned. Despite this cleaning, the waste is still to be allocated to that initial fate as during the period of time it is in the environment it may still be causing problems. Additionally, clean-up activities should be a last resort for controlling plastic pollution, with priority given to stopping its release in the first instance. With this in mind, the land fate actually includes waste which remains on land and that which was collected by street sweepings. Alternatively, the drain fate only includes waste which has been removed or which will eventually end up in waterbodies. This is due to the previously stated assumption that for the drain leakage decision tree, all waste not removed eventually reaches waterbodies. The drain stock therefore only represents this cleaned waste.

The observation methodology accounts for these clean-up activities by including them within the descriptions. For instance, if very little waste is observed on land, but there is very active street sweeping in the area, it is assumed a larger proportion of waste is being dumped to land initially compared to that observed.

### D1: Diffuse voluntary

The leakage type “diffuse voluntary” represents the dumping or open burning of waste from uncollected waste. Considering this, observations should be conducted with the immediate vicinity of areas which lack any form of waste collection service (including informal waste collection services). As the leakage type is voluntary (e.g. a person is in control of how they dispose of it) open burning is included as a fate. The fate decision tree and accompanying descriptive tables are shown in Figure 16 and Table 27 -

Table 30 respectively.

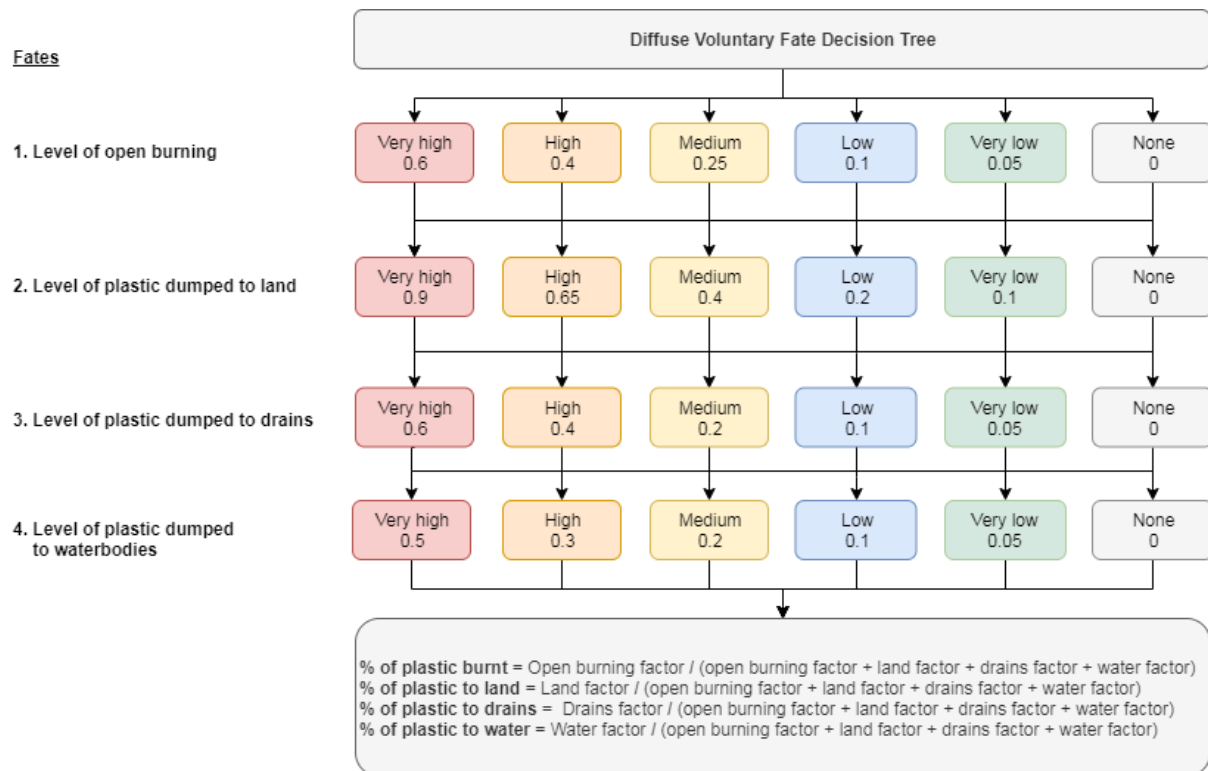

**Figure 16: Fate decision tree for diffuse voluntary leakage types**

**Table 27: Level of diffuse open burning**

Fate Potential	Description	Fate Factor
<b>Very High</b>	In areas without waste collection services, there is evidence that residents routinely burn their waste, with it believed to be the primary means of disposal.	0.6
<b>High</b>	In areas without waste collection services, there is evidence that residents routinely burn their waste, with it believed to be a major but not primary means of disposal.	0.4

<b>Medium</b>	In areas without waste collection services, there is evidence that residents may regularly burn their waste, but this is not believed to be the primary means of disposal.	0.25
<b>Low</b>	In areas without waste collection services, there is sporadic evidence that a minority of the residents may regularly burn waste, but this is not believed to be the primary means of disposal for the majority of residents.	0.1
<b>Very low</b>	In areas without waste collection services, there is sporadic evidence that a minority residents may have occasionally burnt waste, but this is believed to be a rare occurrence.	0.05
<b>None</b>	In areas without waste collection services, there is no evidence of open burning occurring.	0

**Table 28: Level of diffuse dumping to land**

<b>Fate Potential</b>	<b>Description</b>	<b>Fate Factor</b>
<b>Very High</b>	In areas without waste collection services, there is evidence that residents dump the vast majority of their waste to land, with it believed to be the primary means of disposal.  <b>OR</b> In areas without waste collection services, there is evidence that residents routinely dump their waste to land <b>AND</b> regular street sweeping occurs in the areas without waste collection.	0.9
<b>High</b>	In areas without waste collection services, there is evidence that residents routinely dump their waste to land, with it believed to be an important means of disposal.  <b>OR</b> In areas without waste collection services, there is evidence that residents may regularly dump their waste to land <b>AND</b> regular street sweeping occurs in the areas without waste collection.	0.65
<b>Medium</b>	In areas without waste collection services, there is evidence that residents may regularly dump their waste to land, but this is not believed to be the primary means of disposal.  <b>OR</b> In areas without waste collection services, there is sporadic evidence that a minority of residents may regularly dump their waste to land <b>AND</b> occasional street sweeping occurs in the areas without waste collection.	0.4
<b>Low</b>	In areas without waste collection services, there is sporadic evidence that a minority of residents may regularly dump their waste to land, but this is not believed to be the primary means of disposal for the majority of residents.  <b>AND</b> There is no active street sweeping within the areas without waste collection that may be collecting any waste dumped to land.	0.2
<b>Very low</b>	In areas without waste collection services, there is sporadic evidence that a minority of residents may occasionally dump their waste to land, but this is believed to be a rare occurrence.  <b>AND</b> There is no active street sweeping within the areas without waste collection that may be collecting any waste dumped to land.	0.1



<b>None</b>	In areas without waste collection services, there is no evidence of waste being dumped to land.  <b>AND</b>  There is no active street sweeping within the areas without waste collection that may be collecting any waste dumped to land.	0
-------------	--	---

**Table 29: Level of diffuse dumping in drains**

<b>Fate Potential</b>	<b>Description</b>	<b>Fate Factor</b>
<b>Very High</b>	In areas without waste collection services, there is evidence that the majority of the residents routinely dump their waste to drains, with it believed to be the primary means of disposal for many residents.  <b>OR</b>  In areas without waste collection services, there is evidence that many of the residents routinely dump their waste to drains, with it believed to be the primary means of disposal for a minority of residents <b>AND</b> regular cleaning of the drains occurs throughout the entire area.	0.6
<b>High</b>	In areas without waste collection services, there is evidence that many of the residents routinely dump their waste to drains, with it believed to be the primary means of disposal for a minority of residents.  <b>OR</b>  In areas without waste collection services, there is evidence that many residents may regularly dump their waste to drains, but this is not believed to be the primary means of disposal for any residents <b>AND</b> regular cleaning of the drains occurs in the area.	0.4
<b>Medium</b>	In areas without waste collection services, there is evidence that many residents may regularly dump their waste to drains, but this is not believed to be the primary means of disposal for any residents.  <b>OR</b>  In areas without waste collection services, there is sporadic evidence that a minority of residents may regularly dump their waste to drains <b>AND</b> occasional cleaning of the drains occurs in area.	0.2
<b>Low</b>	In areas without waste collection services, there is sporadic evidence that a minority of residents may regularly dump their waste to drains.  <b>AND</b>  There is no active cleaning of the drains within the vicinity that may be collecting any waste dumped to drains.	0.1
<b>Very low</b>	In areas without waste collection services, there is sporadic evidence that a minority of residents may occasionally dump their waste to drains, but this is believed to be infrequent.  <b>AND</b>  There is no active cleaning of the drains within the vicinity that may be collecting any waste dumped to drains.	0.05
<b>None</b>	In areas without waste collection services, there is no evidence of residents dumping waste to drains.  <b>AND</b>	0

	There is no active cleaning of the drains within the vicinity that may be collecting any waste dumped to drains.	
--	--	--

**Table 30: Level of diffuse dumping in water systems**

<b>Fate Potential</b>	<b>Description</b>	<b>Fate Factor</b>
<b>Very High</b>	In areas without waste collection services, almost all of the residents are in close proximity (<500 m) to water systems of which they have access.	0.5
<b>High</b>	In areas without waste collection services, the majority of residents are in close proximity (<500 m) to water systems of which they have access.	0.3
<b>Medium</b>	In areas without waste collection services, around half of residents are in close proximity (<500 m) to water systems of which they have access.	0.2
<b>Low</b>	In areas without waste collection services, a minority of residents are in close proximity (<500 m) to water systems of which they have access.	0.1
<b>Very low</b>	In areas without waste collection services, very few residents are in close proximity (<500 m) to water systems of which they have access.	0.05
<b>None</b>	In areas without waste collection services, there is no presence of waterbodies or access to such water systems is not possible.	0

## **D2: Diffuse involuntary**

The leakage type “diffuse involuntary” represents plastic which is released to the environment from many locations whilst not under someone’s control. For example, this includes plastic which leaks from collection services (i.e. whilst it is waiting to be collected or during the collection), plastic which leaks due to the informal value-chain collection activities, or plastic which leaks whilst being transported to disposal facilities. The widespread (diffuse) nature of the leakages means observation assessments should be done in multiple locations throughout the district, although a degree of focus can be applied to target key areas. For example, if assessing the collection systems, observations should be conducted in the vicinity of the areas with collection services. Alternatively, if assessing leakage from transportation to disposal facilities, observations can be targeted along the relevant transportation routes. The fate decision tree and accompanying descriptive tables are shown in Figure 17 and Table 31 - Table 33 respectively.

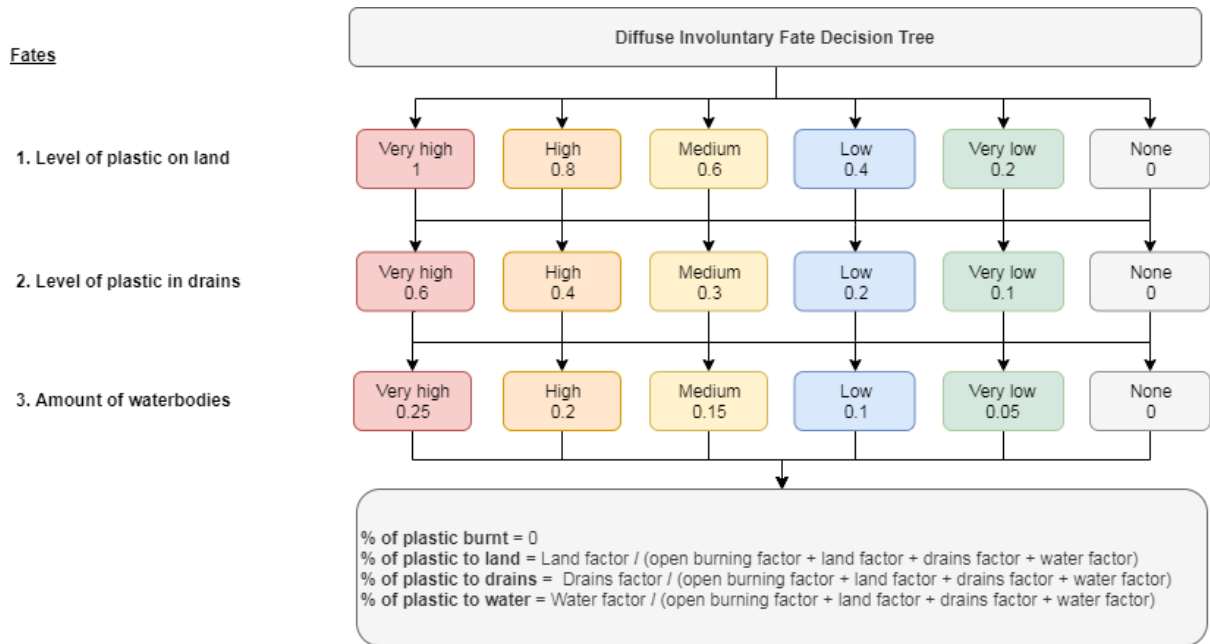

**Figure 17: Fate decision tree for diffuse involuntary leakage types**

**Table 31: Level of diffuse leakage to land**

Fate Potential	Description	Fate Factor
<b>Very High</b>	Throughout all the study area, there is evidence of large quantities of plastic remaining on land (including that caught in vegetation). <b>OR</b> In the majority of the study area, there is evidence of large quantities of plastic remaining on land (including that caught in vegetation) <b>AND</b> regular street sweeping occurs in the majority areas.	1
<b>High</b>	In the majority of the study area, there is evidence of large quantities of plastic remaining on land (including that caught in vegetation). <b>OR</b> In the majority of the study area, there is evidence of small quantities of plastic remaining on land (including that caught in vegetation) <b>AND</b> regular street sweeping occurs in a minority of areas.	0.8
<b>Medium</b>	In the majority of the study area, there is evidence of small quantities of plastic remaining on land (including that caught in vegetation) although a minority of areas show evidence of large quantities. <b>OR</b> Throughout all the study area, there is evidence of small quantities of plastic remaining on land (including that caught in vegetation) <b>AND</b> infrequent street sweeping occurs in the majority of areas.	0.6
<b>Low</b>	Throughout all the study area, there is evidence of small quantities of plastic remaining on land (including that caught in vegetation). <b>OR</b> In a minority of the study area, there is evidence of small quantities of plastic remaining on land (including that caught in vegetation) but the majority of areas show little to no evidence <b>AND</b> infrequent street sweeping occurs in a minority of areas.	0.4

<b>Very low</b>	In a minority of the study area, there is evidence of small quantities of plastic remaining on land (including that caught in vegetation) but the majority of areas show little to no evidence.  <b>AND</b>  There is no active street sweeping that may be collecting any waste leaked to land.	0.2
<b>None</b>	Throughout all the study area, there is no evidence of plastic remaining on land (including that caught in vegetation) <b>AND</b> there is no active street sweeping that may be collecting any waste leaked to land.	0

**Table 32: Level of diffuse leakage to drains**

<b>Fate Potential</b>	<b>Description</b>	<b>Fate Factor</b>
<b>Very High</b>	Throughout all the study area, there is evidence of large quantities of plastic entering storm drains.  <b>OR</b>  In the majority of the study area, there is evidence of large quantities of plastic entering storm drains <b>AND</b> the majority of storm drains are cleaned regularly (several times a year).	0.6
<b>High</b>	In the majority of the study area, there is evidence of large quantities of plastic entering storm drains.  <b>OR</b>  In the majority of the study area, there is evidence of small quantities of plastic entering storm drains although a minority of areas show evidence of large quantities <b>AND</b> a large amount of drains are cleaned once to twice a year	0.4
<b>Medium</b>	In the majority of the study area, there is evidence of small quantities of plastic entering storm drains although a minority of areas show evidence of large quantities.  <b>OR</b>  Throughout all the study area, there is evidence of small quantities of plastic entering storm drains <b>AND</b> a small amount of drains are cleaned once to twice a year.	0.3
<b>Low</b>	Throughout all the study area, there is evidence of small quantities of plastic entering storm drains.  <b>OR</b>  In a minority of the study area, there is evidence of small quantities of plastic entering storm drains but the majority of areas show little to no evidence <b>AND</b> a small amount of drains are cleaned once per year.	0.2
<b>Very low</b>	In a minority of the study area, there is evidence of small quantities of plastic entering storm drains but the majority of areas show little to no evidence <b>AND</b> there is no active street sweeping that may be collecting any waste leaked to land.	0.1
<b>None</b>	Throughout all the study area, there is no evidence of plastic entering storm drains <b>AND</b> there is no active street sweeping that may be collecting any waste leaked to land.	0

**Table 33: Level of diffuse leakage to water**

<b>Fate Potential</b>	<b>Description</b>	<b>Fate Factor</b>
<b>Very High</b>	Almost all of the study area is in close proximity (<1 km) to water systems. Vegetation on the banks of the water systems is very sparse throughout the majority of the study area.	0.25
<b>High</b>	The majority of the study area is in close proximity (<1 km) to water systems. Vegetation on the banks of the water systems is sparse throughout large parts of the study area.	0.2
<b>Medium</b>	The majority of the study area is in close proximity (<1 km) to water systems. Vegetation on the banks of the water systems is dense throughout large parts of the study area.	0.15
<b>Low</b>	The majority of the study area is not in close proximity (>1 km) to water systems. Vegetation on the banks of the water systems is sparse throughout large parts of the study area.	0.1
<b>Very low</b>	The majority of the study area is not in close proximity (>1 km) to water systems. Vegetation on the banks of the water systems is dense throughout large parts of the study area.	0.05
<b>None</b>	All of the study area is not in close proximity (>1 km) to water systems. Vegetation on the banks of the water systems is very dense throughout the majority of the study area.	0

### **D3: Point source voluntary**

The leakage type “point source voluntary” represents plastic rejects which are burnt or dumped to the environment from sorting facilities as a disposal option. This includes both formal and informal sorting facilities, although the latter only applies for the informal service chain due to leakages from the value-chain sorting occurring at the point of collection and therefore typically being diffuse.

Observations should be conducted in the immediate vicinity of the sorting facilities up to a distance estimated to be that at which dumping from that facility is no longer likely to occur. If there are multiple sorting facilities, observations should be conducted outside as many as possible, with the description then chosen which best matches the average situation.

The fate decision tree and accompanying descriptive tables are shown in Figure 18 and Table 34 - Table 37 respectively.

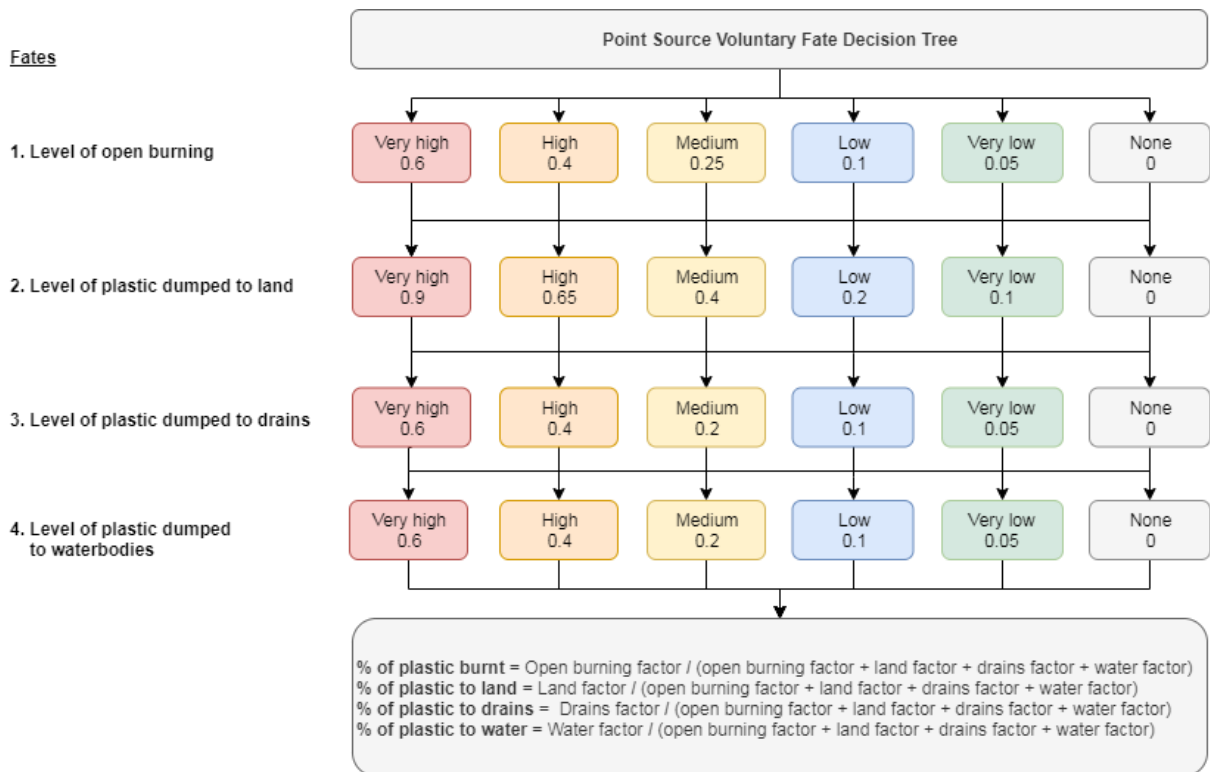

**Figure 18: Fate decision tree for point source voluntary leakage types**

**Table 34: Level of point source open burning**

Fate Potential	Description	Fate Factor
<b>Very High</b>	There is evidence that the majority of sorting facilities routinely burn their sorting rejects, with it believed to be the primary means of disposal.	0.6
<b>High</b>	There is evidence that the majority of sorting facilities routinely burn their sorting rejects, with it believed to be a major but not primary means of disposal.	0.4
<b>Medium</b>	There is evidence that a majority of sorting facilities may occasionally burn their sorting rejects, but this is not believed to be the primary means of disposal.	0.25
<b>Low</b>	There is sporadic evidence that a minority of sorting facilities may regularly burn their sorting rejects, but this is not believed to be the primary means of disposal for the majority.	0.1
<b>Very low</b>	There is sporadic evidence that a minority of sorting facilities may occasionally burn their sorting rejects, but this is believed to be a rare occurrence.	0.05
<b>None</b>	There is no evidence of sorting facilities openly burning their sorting rejects.	0

**Table 35: Level of point source dumping to land**

<b>Fate Potential</b>	<b>Description</b>	<b>Fate Factor</b>
<b>Very High</b>	<p>There is evidence that sorting facilities dump the vast majority of their sorting rejects to land, with it believed to be the primary means of disposal.</p> <p><b>OR</b></p> <p>There is evidence that sorting facilities routinely dump their sorting rejects to land <b>AND</b> regular street sweeping occurs in the vicinity of the sorting facilities.</p>	0.9
<b>High</b>	<p>There is evidence that sorting facilities routinely dump their sorting rejects to land, with it believed to be an important means of disposal.</p> <p><b>OR</b></p> <p>There is evidence that sorting facilities may regularly dump their sorting rejects to land <b>AND</b> regular street sweeping occurs in the vicinity of the sorting facilities.</p>	0.65
<b>Medium</b>	<p>There is evidence that sorting facilities may regularly dump their sorting rejects to land, but this is not believed to be the primary means of disposal.</p> <p><b>OR</b></p> <p>There is sporadic evidence that a minority of sorting facilities may regularly dump their waste to land <b>AND</b> occasional street sweeping occurs in the vicinity of the sorting facilities.</p>	0.4
<b>Low</b>	<p>There is sporadic evidence that a minority of sorting facilities may regularly dump their sorting rejects to land, but this is not believed to be the primary means of disposal for the majority.</p> <p><b>AND</b></p> <p>There is no active street sweeping within the vicinity of the sorting facilities that may be collecting any waste dumped to land.</p>	0.2
<b>Very low</b>	<p>There is sporadic evidence that a minority of sorting facilities may occasionally dump their sorting rejects to land, but this is believed to be a rare occurrence.</p> <p><b>AND</b></p> <p>There is no active street sweeping within the vicinity of the sorting facilities that may be collecting any waste dumped to land.</p>	0.1
<b>None</b>	<p>There is no evidence of sorting facilities dumping their sorting rejects to land.</p> <p><b>AND</b></p> <p>There is no active street sweeping within the vicinity of the sorting facilities that may be collecting any waste dumped to land.</p>	0

**Table 36: Level of point source dumping in drains**

<b>Fate Potential</b>	<b>Description</b>	<b>Fate Factor</b>
<b>Very High</b>	<p>There is evidence that the majority of the sorting facilities routinely dump their sorting rejects to drains, with it believed to be the primary means of disposal for many.</p> <p><b>OR</b></p>	0.6

	There is evidence that many of the sorting facilities routinely dump their sorting rejects to drains, with it believed to be the primary means of disposal for a minority of sorting facilities <b>AND</b> regular cleaning of the drains occurs in the vicinity of the sorting facilities.	
<b>High</b>	There is evidence that many of the sorting facilities routinely dump their sorting rejects to drains, with it believed to be the primary means of disposal for a minority of sorting facilities. <b>OR</b> There is evidence that many sorting facilities may regularly dump their sorting rejects to drains, but this is not believed to be the primary means of disposal <b>AND</b> regular cleaning of the drains occurs in the vicinity of the sorting facilities.	0.4
<b>Medium</b>	There is evidence that many of the sorting facilities may regularly dump their sorting rejects to drains, but this is not believed to be the primary means of disposal for any sorting facilities. <b>OR</b> There is sporadic evidence that a minority of sorting facilities may regularly dump their sorting rejects to drains <b>AND</b> occasional cleaning of the drains occurs in vicinity of the sorting facilities.	0.2
<b>Low</b>	There is sporadic evidence that a minority of sorting facilities may regularly dump their sorting rejects to drains <b>AND</b> there is no active cleaning of the drains within the vicinity of the sorting facilities that may be collecting any waste dumped to drains.	0.1
<b>Very low</b>	There is sporadic evidence that a minority of sorting facilities may occasionally dump their sorting rejects to drains, but this is believed to be infrequent <b>AND</b> there is no active cleaning of the drains within the vicinity of the sorting facilities that may be collecting any waste dumped to drains.	0.05
<b>None</b>	There is no evidence of sorting facilities dumping sorting rejects to drains <b>AND</b> there is no active cleaning of the drains within the vicinity that may be collecting any waste dumped to drains.	0

**Table 37: Level of diffuse dumping in water systems**

<b>Fate Potential</b>	<b>Description</b>	<b>Fate Factor</b>
<b>Very High</b>	Almost all of the sorting facilities are in close proximity (<500 m) to water systems of which they have access.	0.6
<b>High</b>	The majority of sorting facilities are in close proximity (<500 m) to water systems of which they have access.	0.4
<b>Medium</b>	Around half of sorting facilities are in close proximity (<500 m) to water systems of which they have access.	0.2
<b>Low</b>	A minority of sorting facilities are in close proximity (<500 m) to water systems of which they have access.	0.1
<b>Very low</b>	Very few sorting facilities are in close proximity (<500 m) to water systems of which they have access.	0.05
<b>None</b>	There are no sorting facilities in close proximity (<500 m) to water systems or access to such water systems is not possible.	0



#### D4: Point source involuntary

The leakage type “point source involuntary” represents plastic which is released to the environment from a number of fixed point sources whilst not under someone’s control. Point sources for this leakage type include disposal facilities. As with the point source voluntary leakage type, observations should be conducted in the vicinity of the dumpsites. If multiple dumpsites exist, then observations should be conducted outside as many as possible, with descriptions chosen which best match the average situation.

The fate decision tree and accompanying descriptive tables are shown in Figure 19 and Table 38 - Table 40 respectively.

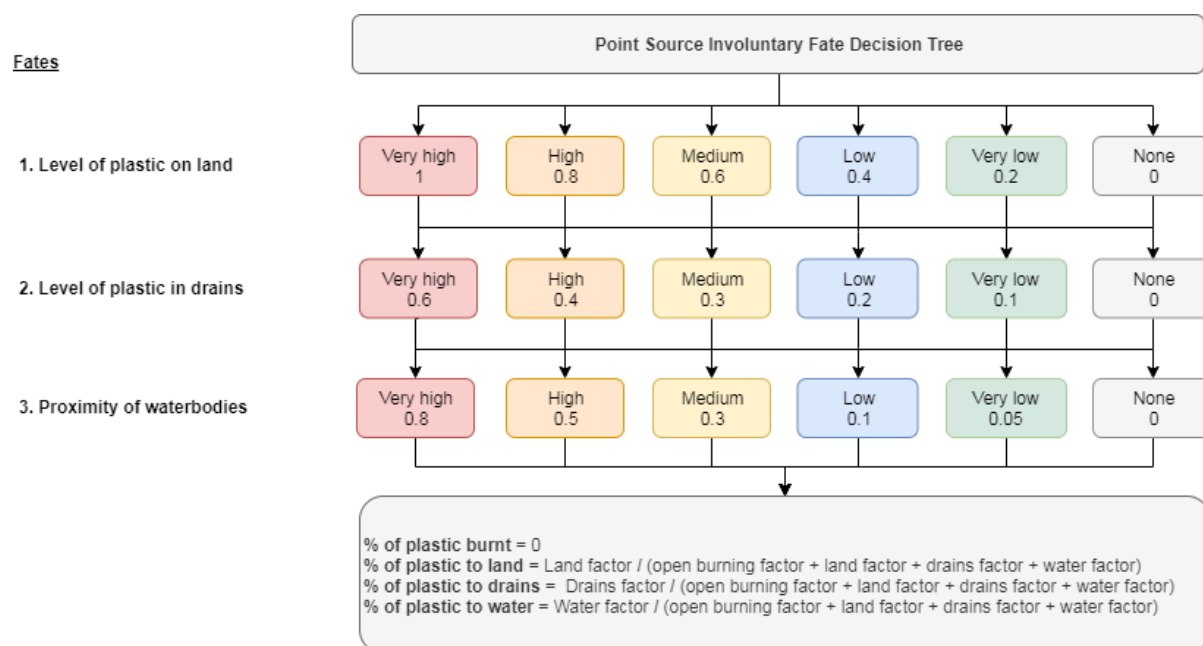

Figure 19: Fate decision tree for point source involuntary leakage types

Table 38: Level of point source leakage to land

Fate Potential	Description	Fate Factor
<b>Very High</b>	In the vicinity of the point sources, there is evidence of large quantities of plastic remaining on land (including that caught in vegetation). <b>OR</b> In the vicinity of the point sources, there is evidence of large quantities of plastic remaining on land (including that caught in vegetation) <b>AND</b> regular street sweeping occurs.	1
<b>High</b>	In the vicinity of the point sources, there is evidence of large quantities of plastic remaining on land (including that caught in vegetation). <b>OR</b> In the vicinity of the point sources, there is evidence of small quantities of plastic remaining on land (including that caught in vegetation) <b>AND</b> occasional street sweeping occurs.	0.8

<b>Medium</b>	In the vicinity of the point sources, there is evidence of small quantities of plastic remaining on land (including that caught in vegetation) although some areas show evidence of large quantities.  <b>OR</b> In the vicinity of the point sources, there is evidence of small quantities of plastic remaining on land (including that caught in vegetation) <b>AND</b> infrequent street sweeping occurs.	0.6
<b>Low</b>	In the vicinity of the point sources, there is evidence of small quantities of plastic remaining on land (including that caught in vegetation).  <b>OR</b> In the vicinity of the point sources, there is evidence of small quantities of plastic remaining on land (including that caught in vegetation) but the majority of area show little to no evidence <b>AND</b> very infrequent street sweeping occurs.	0.4
<b>Very low</b>	In the vicinity of the point sources, there is evidence of small quantities of plastic remaining on land (including that caught in vegetation) but the majority of areas show little to no evidence <b>AND</b> there is no active street sweeping that may be collecting any waste leaked to land.	0.2
<b>None</b>	In the vicinity of the point sources, there is no evidence of plastic remaining on land (including that caught in vegetation) <b>AND</b> there is no active street sweeping that may be collecting any waste leaked to land.	0

**Table 39: Level of point source leakage to drains**

<b>Fate Potential</b>	<b>Description</b>	<b>Fate Factor</b>
<b>Very High</b>	In the vicinity of the point sources, there is evidence of large quantities of plastic entering storm drains.  <b>OR</b> In the vicinity of the point sources, there is evidence of large quantities of plastic entering storm drains <b>AND</b> the majority of storm drains are cleaned regularly (several times a year).	0.6
<b>High</b>	In the vicinity of the point sources, there is evidence of large quantities of plastic entering storm drains.  <b>OR</b> In the vicinity of the point sources, there is evidence of small quantities of plastic entering storm drains although a minority of areas show evidence of large quantities <b>AND</b> a large amount of drains are cleaned once to twice a year	0.4
<b>Medium</b>	In the vicinity of the point sources, there is evidence of small quantities of plastic entering storm drains although a minority of areas show evidence of large quantities.  <b>OR</b> In the vicinity of the point sources, there is evidence of small quantities of plastic entering storm drains <b>AND</b> a small amount of drains are cleaned once to twice a year.	0.3
<b>Low</b>	In the vicinity of the point sources, there is evidence of small quantities of plastic entering storm drains.	0.2

	<b>OR</b> In the vicinity of the point sources, there is evidence of small quantities of plastic entering storm drains but the majority of areas show little to no evidence <b>AND</b> a small amount of drains are cleaned once per year.	
<b>Very low</b>	In the vicinity of the point sources, there is evidence of small quantities of plastic entering storm drains but the majority of areas show little to no evidence <b>AND</b> there is no active street sweeping that may be collecting any waste leaked to land.	0.1
<b>None</b>	In the vicinity of the point sources, there is no evidence of plastic entering storm drains <b>AND</b> there is no active street sweeping that may be collecting any waste leaked to land.	0

**Table 40: Level of diffuse leakage to water**

<b>Fate Potential</b>	<b>Description</b>	<b>Fate Factor</b>
<b>Very High</b>	Almost all of the point sources are in close proximity (<1 km) to water systems. Vegetation on the banks of the water systems is very sparse.	0.8
<b>High</b>	The majority of the point sources are in close proximity (<1 km) to water systems. Vegetation on the banks of the water systems is sparse.	0.5
<b>Medium</b>	The majority of the point sources are in close proximity (<1 km) to water systems. Vegetation on the banks of the water systems is dense.	0.3
<b>Low</b>	The majority of the point sources are not in close proximity (>1 km) to water systems. Vegetation on the banks of the water systems is sparse.	0.1
<b>Very low</b>	The majority of the point sources are not in close proximity (>1 km) to water systems. Vegetation on the banks of the water systems is dense.	0.05
<b>None</b>	All of the point sources are not in close proximity (>1 km) to water systems. Vegetation on the banks of the water systems is very dense.	0

## Step E: Build and compare scenarios (optional)

As explained in Chapter 3, the WFD allows for scenario-building in order to enable users to estimate the potential impact of applying interventions within the waste management system. For example, the user could simulate how increasing the collection coverage by set amounts would impact the rest of the waste management system, including the amounts of plastic leaking into water ways.

### Comparison to “Baseline data entry”

The data requirements of the “Scenario data entry” sheet differ compared to those of the “Baseline data entry” sheet in that they follow a simpler linear approach (waste generation > collection > treatment > disposal). This is due to the scenarios not necessarily having to be based on ground-based measurements and therefore they don't have the same restrictions that were applied to the baseline data for quality control. For example, in the baseline method, the collection coverage and uncollected waste is calculated by comparing measurements of what is treated and disposed compared to that generated at source. The “Baseline data entry” sheet uses measured weights in tonnes as inputs. In contrast, the “Scenario data entry” does not require these measured data points as it assesses possible hypothetical scenarios. Instead, the “Scenario data entry” sheet largely uses percentages to split the initial waste generation across each stage of the solid waste management system.

This approach has both advantages and challenges. By allowing percentage based data inputs for each stage of the waste management system, interventions can be targeted at aspects that would not be feasible using the baseline approach. For instance, collection coverage (%) can be specified as an input and therefore analysed as an intervention. However, challenges with this scenario method involve how the user is able to adequately select percentages for these inputs if these cannot be directly measured.

### Running scenarios

The above challenges can be partially negated by applying the scenarios in one of two ways:

- 1) Standalone testing
- 2) Relative to baseline scenario

In the **standalone testing method**, users can simply test various scenarios by estimating the data input values without having performed any measurements themselves. Here accuracy of the data inputs is not crucial as instead users are assessing general trends that arise from altering the different inputs.

In contrast, in the **relative to baseline scenario method**, users are expected to have already conducted the data collection for the baseline approach, and therefore are assumed to want to systematically assess the impact of applying different interventions. In this method, all inputs should be set equal to that of the “Baseline data entry” sheet, except those being altered as part of an intervention. The Waste Flow Diagram makes this process easier for the user by showing the baseline data entry values alongside that of the scenarios input cells, thereby allowing users to replicate these. For inputs which have different units or were not required in the baseline approach (i.e. collection coverage) the WFD also converts these into the correct format. However, due to the difference in calculation methods explained above, the scenario is unlikely to match the baseline results exactly, even when entering identical data, although variations are usually minor. If variations are significant, we suggest to perform all scenario testing in the standalone method.

Whilst users are able to alter the values in the data input section “5. Plastic pollution levels per fate”, this should only be performed in the standalone testing method, or for the relative to baseline scenario method if users wish to test an intervention that applies to the fates. For example, interventions for increasing street sweepings should have the land percentages increased, whilst interventions for improving drain cleaning should have the drain percentages increased.

## Step F: Results

### F1: Summary tables

The “Results summary” sheet within the excel model automatically summarises all results into two tables. Both tables are designed in printable sizes (fitting A4). Table 41 presents the results relating to waste flows throughout the MSWM system. Results are outlined for both total MSW generated as well as total plastic waste generated, and are measured in tonnes per year and as percentages. Of the results shown, the “collected waste” and the “managed in controlled facilities” results are those to be used for reporting of the SDG 11.6.1 indicators.

Table 42: Results of unmanaged plastic waste flows as reported by the WFD (dummy results). Table 42 presents the results for the unmanaged plastic waste. This includes the total amount of unmanaged plastic waste, the different sources and relative contribution of plastic leakage towards unmanaged plastic waste, as well as the final fates/sinks of this plastic pollution. The table further provides a summary indicator of the plastic pollution (measured using two alternative units) that can be used as a benchmark.

**Table 41: Results of plastic and MSW flows within the MSWM system as reported by the WFD (dummy results).**

	Plastic waste				Municipal Solid Waste				Unit
	Baseline	Scenario 1	Scenario 2	Scenario 3	Baseline	Scenario 1	Scenario 2	Scenario 3	
Municipal solid waste generation	20,696	20,696	20,696	20,696	229,950	229,950	229,950	229,950	Tonnes/year
Municipal solid waste generation	57	57	57	57	630	630	630	630	Tonnes/day
Collected waste	12,969	15,805	17,875	19,944	123,929	149,081	172,076	195,071	Tonnes/year
Collected waste	63%	76%	86%	96%	54%	65%	75%	85%	% of waste generation
Uncollected waste	7,727	4,890	2,821	751	106,021	80,869	57,874	34,879	Tonnes/year
Uncollected waste	37%	24%	14%	4%	46%	35%	25%	15%	% of waste generation
Waste sorted for recovery <i>(excludes energy from waste)</i>	5,110	5,352	5,680	6,008	17,520	18,172	19,350	20,527	Tonnes/year
Waste sorted for recovery <i>(excludes energy from waste)</i>	25%	26%	27%	29%	8%	8%	8%	9%	% of waste generation
Waste sorted for recovery by formal sector <i>(excludes energy from waste)</i>	7%	9%	10%	11%	2%	3%	3%	4%	% of waste generation
Waste sorted for recovery by informal sector <i>(excludes energy from waste)</i>	18%	17%	17%	18%	5%	5%	5%	5%	% of waste generation
Energy from waste	365	497	579	662	3,650	4,561	5,321	6,081	Tonnes/year
Energy from waste	2%	2%	3%	3%	2%	2%	2%	3%	% of waste generation
Disposal in disposal facilities	7,300	9,924	11,578	13,232	102,565	126,315	147,368	168,420	Tonnes/year
Disposal in disposal facilities	35%	48%	56%	64%	45%	55%	64%	73%	% of waste generation
Managed in controlled facilities	0	0	8,919	19,902	0	0	86,019	195,028	Tonnes/year
Managed in controlled facilities	0%	0%	43%	96%	0%	0%	37%	85%	% of waste generation

**Table 42: Results of unmanaged plastic waste flows as reported by the WFD (dummy results).**

	Plastic waste				Unit
	Baseline	Scenario 1	Scenario 2	Scenario 3	
Unmanaged plastic waste	7,931	4,937	2,875	812	Tonnes/year
Unmanaged plastic waste	38%	24%	14%	4%	% of plastic waste generation
<i>Contribution from uncollected waste</i>	97.43%	99.06%	98.13%	92.49%	% of mismanaged plastic waste
<i>Contribution from collection service</i>	1.81%	0.25%	0.50%	2.04%	% of mismanaged plastic waste
<i>Contribution from informal value-chain collection</i>	0.38%	0.07%	0.12%	0.42%	% of mismanaged plastic waste
<i>Contribution from formal sorting</i>	0.09%	0.18%	0.36%	1.47%	% of mismanaged plastic waste
<i>Contribution from informal sorting</i>	0.15%	0.16%	0.32%	1.30%	% of mismanaged plastic waste
<i>Contribution from transportation</i>	0.00%	0.00%	0.00%	0.00%	% of mismanaged plastic waste
<i>Contribution from disposal facilities</i>	0.13%	0.28%	0.56%	2.28%	% of mismanaged plastic waste
Plastic waste retained on land	3,394	2,084	1,216	351	Tonnes/year
Plastic waste retained on land	43%	42%	42%	43%	% of mismanaged plastic waste
Plastic waste openly burnt	2,042	1,296	753	210	Tonnes/year
Plastic waste openly burnt	26%	26%	26%	26%	% of mismanaged plastic waste
Plastic waste cleaned from drains	334	207	120	34	Tonnes/year
Plastic waste cleaned from drains	4%	4%	4%	4%	% of mismanaged plastic waste
Plastic waste to water systems	2,160	1,350	785	218	Tonnes/year
Plastic waste to water systems	27%	27%	27%	27%	% of mismanaged plastic waste
Plastic waste to water systems	10%	7%	4%	1%	% of plastic waste generation
<i>Contribution directly entering water systems</i>	38%	39%	39%	39%	% of plastic in water systems
<i>Contribution entering via storm drains</i>	62%	61%	61%	61%	% of plastic in water systems
Plastic to water systems per person	2.2	1.3	0.8	0.2	kg per person/year
Plastic to water systems per person	72	45	26	7	no. PET bottles per person/year*
Plastic to water systems	25	16	9	3	no. of olympic swimming pools/year**
Plastic to water systems	3,177	1,985	1,155	321	no. of waste trucks/year***

\*Mass of 1.5 litre PET bottle: 30 g

\*\*Pool volume: 2,500 m<sup>3</sup>, Density mixed plastic waste: 34 kg/m<sup>3</sup>

\*\*\*Volume truck: 20 m<sup>3</sup>, Density mixed plastic waste: 34 kg/m<sup>3</sup>

## F2: Flow Diagrams

All outcomes obtained through the WFD assessment can be visualised in standardised diagrams. This can be achieved by following the instruction provided within the WFD model and using the free web-based tool "SankeyMatic" (<http://SankeyMatic.com/>).

The WFD allows the generation of two types of diagrams:

- 1) **Basic Sankey Diagram:** This type of diagram shows the main MSWM related flows in the case study (Figure 20). When plotting for plastic, this option does not visualise the plastic leakages (Figure 21). When plotting for anything other than plastic, this option does not show the fates, but instead only shows waste entering the environment in general.
- 2) **Complex Sankey Diagram:** This diagram includes all flows considered under the basic option as well as the leakages when considering plastic (Figure 22). As with the Basic Sankey Diagram, when plotting the flows of non-plastic items (including all MSW), the fates are not included due to these only being calculated for the plastic flows. Instead the diagram generalises the unmanaged waste as being in the environment.

When you open the sheet named "Flow Diagrams" in excel, the first thing you will see is the system map (Figure 4). Scroll down and you will find three grey boxes containing all information you need to create the Sankey Diagrams. For reference, these instructions are as follows:

### Instructions for plotting the results in a Sankey diagram using SankeyMatic:

- 1) Select which scenario and material you would like to plot by changing the drop down menu at the top left of this page.
- 2) Decide which Sankey Diagram you wish to plot (basic or complex).
- 3) Copy the grey code from the grey box.
- 4) Go to <http://SankeyMatic.com/build>.
- 5) Paste the code into the "Inputs:" box.
- 6) Delete any quotation marks present at the start and the end of the copied code.

### Optional instructions for formatting as shown in examples:

- 7) In the "Size, Spacing and Shape" options, change the diagram width to 800px and the node width to 5px.
- 8) In the "Colors" options change the "Node Colors" option to "Use a single color" and select the colour as black. Set the "Flow Opacity" to 1.0.
- 9) In the "Labels & Units" options, uncheck the "Show labels" box. We will manually add these later.
- 10) If necessary, drag the nodes of the flows around for a more suitable layout. This must be performed last as any subsequent changes to the style of the Sankey diagram will revert this step.
- 11) Once you are satisfied with the format, export the image using the "Export Diagram" option box.
- 12) Open the image in a software of choice (i.e. Microsoft Powerpoint) and add the text labels and quantities. The Waste Flow Diagram has a prebuilt downloadable Powerpoint template to assist in creating the Sankey Diagrams, available at <http://plasticpollution.leeds.ac.uk>. Labels in both mass and percentages are displayed in the 'Flow diagrams' sheet in the WFD to allow easy entry.

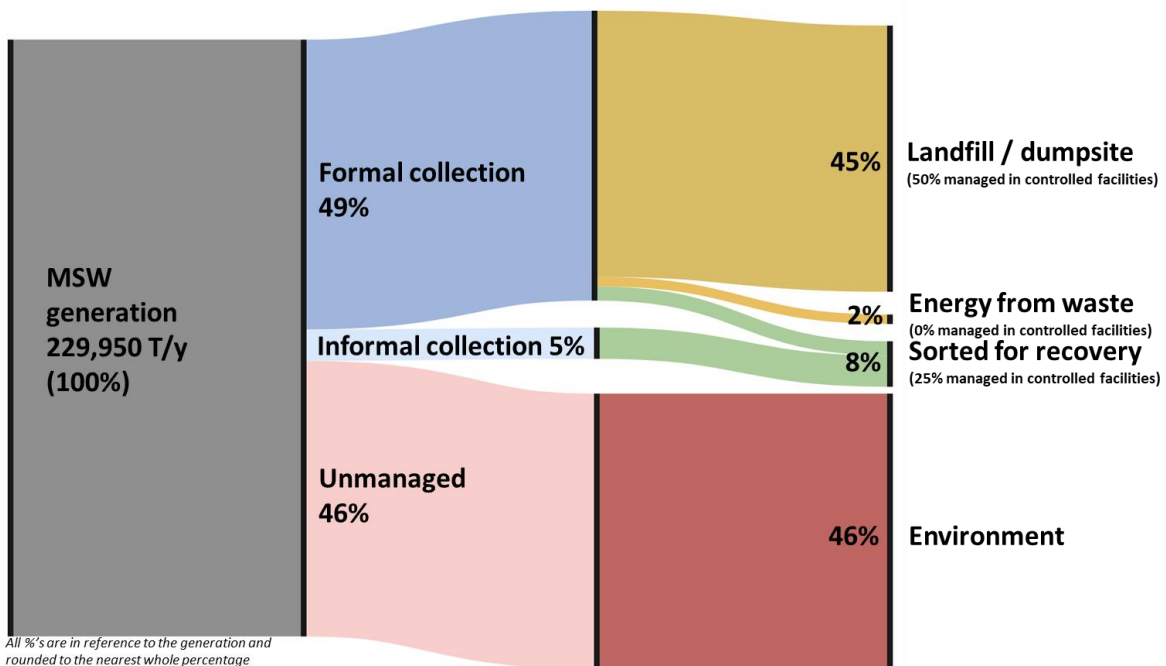

Figure 20: Waste flow diagram showing the flows for all MSW (based on basic Sankey diagram and using dummy data)

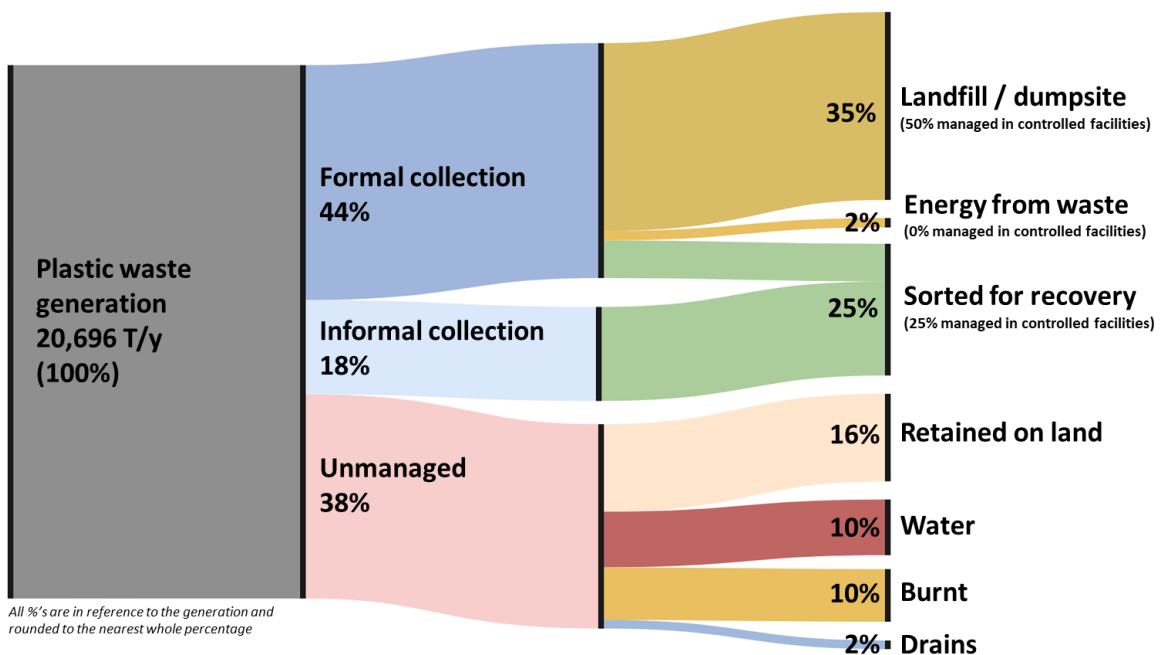
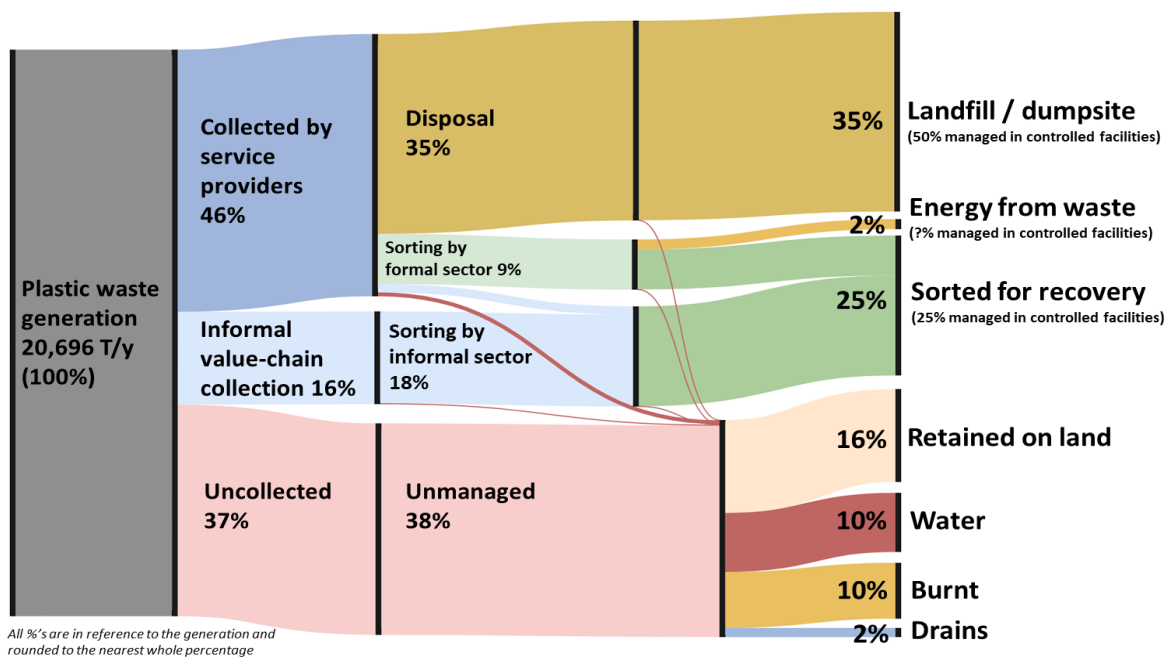

Figure 21: Plastic waste flow diagram showing the flows for all plastic waste (based on basic Sankey diagram and using dummy data)





**Figure 22: Plastic waste flow diagram showing the flows for all plastic waste (based on complex Sankey diagram and using dummy data)**

### F3: Interpreting the results

The results of the WFD can be visualised in a number of formats. Those presented in Table 41 relate to the general MSW flows in the MSWM system and can be used for reporting the SDG 11.6.1 sub-indicators: waste generation, collection coverage and the amount of waste managed in controlled facilities. Units are typically given in both tonnes per year and as a percentage of waste generation so as to inform on both the magnitude and its importance compared to the rest of the flows.

Table 42, instead focuses on the plastic waste flows, specifically going into detail on the leakages of plastic and where they end up in the environment (i.e. fates). This data shows the breakdown on plastic leakage by each stage of the solid waste management system, again in both absolute masses and percentage formats. This allows users to quickly identify the major leakage points and therefore target interventions. Similarly, the scenarios shown for these results can convey the degree to which certain interventions if applied would impact the plastic pollution. In addition to this, the fates for all of the plastic leakage are elaborated upon. Particular detail is given to the water fate, with this converted into several easy to visual and communicate examples such as number of PET bottles per person, number of Olympic sized swimming pools, and number of waste trucks.

Lastly, the Sankey diagrams shown in section F2, visualise the results in a clear and easy to interpret manner so as to allow dissemination to non-waste experts such as government officials. Whilst avoiding the detail of the flow diagram, the main flows of the system can be identified with percentages allocated to each.

**Note:** It is highly likely that for some case studies the mass or percentage of plastic estimated to enter water systems is lower than expected. It is important however to consider that these estimates likely differ from previous estimates such as those which apply generic percentages of waste entering water for all mismanaged waste by taking a more structure and detailed approach accounting for the waste management practices. Likewise, plastic has a very low density, therefore although the mass or weight-% may be relatively small, this may still be significant in terms of volume or number of items.

## **Step G: Sharing your results**

### **Why share your case study with us?**

Whilst the Waste Flow Diagram (WFD) is freely distributed under the creative commons (CC-BY-ND) license, we encourage users include the development team in the application of the toolkit and sharing of the results. This has a number of mutual benefits such as:

1. Allows us to help you in applying the toolkit
2. Help in providing quality assurance
3. Increase the availability of data for both waste management and marine litter
4. Improve the robustness of the WFD
5. Build a community of practice for data driven marine litter prevention

### **What information should be shared?**

We encourage users to share the following information with us:

1. Completed case study reports and WFD excel sheets
2. If possible, primary data acquired during field visits for the application of the WFD. This will enable us to provide quality assurance."

### **How to share your case study with us**

Whether you are just starting out applying the Waste Flow Diagram, or have a completed case study, please get in contact at [wfd.plasticpollution@leeds.ac.uk](mailto:wfd.plasticpollution@leeds.ac.uk) to see how we may help.

### **Where will data be stored?**

After quality assurance checks, your case study data and results will be stored and made publically available from the University of Leeds Repository under the Waste Flow Diagram collection. All data will be managed in line with GDPR regulations.

## Annexes

### Annex 1: Elements within the system map

We can distinguish two types of elements in the system map: processes and flows. The processes represent either MSWM system stages, unmanaged fractions or final fates. These are all explained under section “Key concepts”. All flows within the system map are presented in Table 43 and Table 44.

#### MSWM related flows

Table 43 shows those processes related to the MSWM along with descriptions of each flow and the calculations used for determining them. Note, time elements have been removed from the equation as these may differ based on individuals data sources, however the inputs should be converted to a yearly timeframe as required by the WFD.

**Table 43: Flows of the system map related to MSWM**

Flow number	Flow name	Description	Calculation
F1	MSW Generation	This flow represents all MSW generated within the study case area. For definition of MSW refer to section “Key concepts”.	<p>Total MSW generation is calculated based on the total population and per capita generation rate.</p> <p>Plastic: total generated plastic waste is calculated multiplying the total MSW generated by the share of plastic in composition data given.</p> <p><b>F1 = Population × MSW generation rate</b></p>
F2	Waste captured by collection services	<p>This flow includes all generated MSW that will be collected by one of the following collection services:</p> <ul style="list-style-type: none"> <li>• Formal mixed waste collection</li> <li>• Formal source separated collection</li> <li>• Informal mixed waste collection</li> </ul> <p>This flow represents the amounts before the collection happens.</p>	<p>The flow is retrospectively calculated. The tool automatically sums the amounts given to F7, F8, the share of F9 collected by informal mixed waste collection services (and not value chain), F10 and their corresponding leakages (F12 and F14).</p> <p>Refer to step B “B4: Data point 7 - ” for further details on how to determine the share of F9.</p> <p><b>F2 = (F5 + F7) / (1 - <math>\frac{\% \text{ leaking from collection services}}{100}</math>)</b></p>

F3	Materials collected by informal value chain	<p>This flow only includes those generated materials that will be collected by informal waste pickers, but have not been collected yet. Pickers are normally active at disposal sites and streets, but they might also separate recyclables from collection vehicles while they perform the collection service. Usually waste pickers target materials with a recycling value and existing market (e.g. PET).</p> <p>Materials separated during informal mixed waste collection are accounted in F2.</p>	<p>This flow is retrospectively calculated. The tool automatically sums the share of F9 collected by the informal value chain (and not informal service chain) and the corresponding leakages (F15 and F13).</p> <p>Refer to step B "B4: Data point 7 - " for further details on how to determine the share of F9 for this flow.</p> $F3 = F6 / \left( 1 - \frac{\% \text{ leaking from informal value chain collection}}{100} \right)$
F4	Uncollected waste	<p>Uncollected waste refers to all waste generated by the generators which does not end up in either a recovery or disposal facility. It is either never collected or collected by primary collection services but then dumped in a disposal site not categorized as disposal facility.</p>	<p>Uncollected waste is calculated through mass balance, by subtracting the amounts that arrive in recovery and disposal facilities as well as their leakages from the total MSW generated (F1).</p> $F4 = F1 - F2 - F3$
F5	Collection service waste diverted from disposal	<p>This flow represents all MSW collected by collection services which is diverted to a sorting facility or an energy recovery facility but has not been sorted or treated yet.</p>	<p>This flow is retrospectively calculated. The tool automatically sums the amounts assigned to F8, the share of F9 collected by informal mixed waste collection services (and not value chain), F10 as well as their leakages (F14, F15).</p> <p>Refer to step B "B4: Data point 7 - " for further details on how to determine the share of F9.</p> $F5 = \left[ \frac{F8}{1 - \% \text{ leaking from formal sorting}/100} \right] + F10 + \left[ \frac{F9 \times \% \text{ of waste collected by informal collection services}}{1 - \% \text{ leaking from informal service chain sorting}/100} \right]$
F6	Material collected by informal value chain	<p>This flow represents the amounts of recyclables that have been collected by the informal value chain but have not been sorted yet.</p>	<p>This flow is retrospectively calculated. The tool calculates the share of F9 collected by the informal value chain (and not service chain).</p> $F6 = F9 - F9 \times \% \text{ of waste collected by informal collection services}$

			Refer to step B “B4: Data point 7 - ” for further details on how to determine the share of F9.
F7	Direct to disposal (untreated)	This flow represents the amounts that are directed to disposal but have not been transported yet.	<p>This flow is retrospectively calculated. The tool automatically sums the amounts arriving to disposal facilities (F11) and the leakages generated during transportation (F16).</p> $F7 = F11 / \left( 1 - \frac{\% \text{ leaking during transportation}}{100} \right)$
F8	Sorted for recovery from formal collection	This flow includes all MSW that ends up in formal sorting facilities which sort materials for their recovery. This flow excludes materials that were sorted for energy from waste.	<p>The data for this flow can be obtained through primary data collection using the SDG 11.6.1 methodology.</p> <p><b>F8 = Baseline data entry no. 6</b></p>
F9	Sorted for recovery from informal collection	This flow includes all MSW materials that have been originally collected and therefore sorted by the informal sector. This flow excludes materials that were informally sorted for energy from recovery.	<p>The data for this flow can be obtained through primary data collection using the SDG 11.6.1 methodology.</p> <p><b>F9 = Baseline data entry no. 7</b></p>
F10	Energy from waste	This flow represents the amounts of MSW that are treated in an energy recovery plant.	<p>The data for this flow can be obtained through primary data collection using the SDG 11.6.1 methodology.</p> <p><b>F10 = Baseline data entry no. 5</b></p>
F11	Waste for disposal	This flow represents the amounts of MSW that are discharged in all existing disposal facilities within the case study.	<p>The data for this flow can be obtained through primary data collection using the SDG 11.6.1 methodology. Waste collected by the informal sector at disposal sites has been deducted from F11 and is included in F3 (see also simplifications).</p> <p><b>F11 = Baseline data entry no. 4</b></p>

### Plastic leakage related flows

Table 44 shows those flows related to the plastics that leaked into the environment.

**Table 44: Flows of the system map related to plastic leakage**

Flow number	Flow name	Includes	Excludes
F12	Plastic leakage from collection services	<ul style="list-style-type: none"> <li>Leakages occurring during storage of the waste before it is collected (street containers, street dumps, etc.)</li> <li>Leakages occurring during loading of the collection trucks (both formal and informal service chains)</li> <li>Leakages occurring during primary collection (both formal and informal service chains)</li> <li>Leakages occurring due to multiple handling of waste (i.e. transfer stations) (both formal and informal service chains)</li> <li>Leakages occurring during source separated formal collection of waste fractions</li> </ul>	<ul style="list-style-type: none"> <li>Leakages from the informal value-chain sector. These are counted separately within F13.</li> </ul> <p><b>F12 = F2 × % leaking from collection services</b></p>
F13	Plastic leakage from informal value chain collection	<ul style="list-style-type: none"> <li>Leakages occurring during the extraction of recyclables from street containers</li> <li>Leakages occurring during transportation of these recyclables to sorting facilities</li> </ul>	<ul style="list-style-type: none"> <li>Leakages occurring during informal mixed waste collection. These are counted within F12</li> <li>The amounts (of valuable material) collected informally directly from households or disposal sites are assumed not to generate any leakage (would be loss of value, which will be avoided by waste pickers).</li> </ul> <p><b>F13 = F3 × % leaking from informal value chain collection</b></p>
F14	Plastic leakage from formal sorting	<ul style="list-style-type: none"> <li>Leakages generated due to a bad management given to the rejects</li> </ul>	<p><b>F14 = F8 × % plastic leaking from formal sorting</b></p>
F15	Plastic leakage from informal sorting	<ul style="list-style-type: none"> <li>Leakages generated due to a bad management given to the rejects</li> </ul>	<p><b>F15 = F9 × % of waste collected by informal collection services × % leaking from informal sorting</b></p>

F16	Plastic leakage during transportation to disposal	<ul style="list-style-type: none"> <li>Leakages occurring during transportation of MSW to final disposal facilities</li> </ul>	<ul style="list-style-type: none"> <li>Leakages occurring during transportation of MSW to sorting or energy recovery facilities</li> </ul> <p><b>F16 = F7 × % leaking during transportation</b></p>
F17	Plastic leakage from disposal	<ul style="list-style-type: none"> <li>Leakages due to flooding and landslide events from disposal facilities</li> <li>Leakages due to wind from disposal facilities</li> </ul>	<ul style="list-style-type: none"> <li>Leakages from other disposal sites not categorized as disposal facilities. These are counted as uncollected waste within F4.</li> <li>Informal sorting at the landfill is assumed to cause no leakage, as any rejects are dropped back to the landfill.</li> <li>Any formal sorting activities at the landfill have their leakages accounted for, within F14.</li> </ul> <p><b>F17 = F11 × % leaking from disposal</b></p>
F18	Plastic entering water systems (directly or via transportation over land)	Plastic waste which has or will at any point in time enter water systems and remain as such. For definition of what is counted as water systems, see section “Key concepts”.	$F18 = \sum_{i=12}^{17} F_i \times \% \text{ to water from each leakage}$ <p><b>+ F<sub>4</sub> × % to water from uncollected waste</b></p>
F19	Plastic waste entering storm drains	Plastic waste which has or will at any point in time enter storm water drains.	<ul style="list-style-type: none"> <li>Plastic waste within the sanitary sewer system (unless this is combined with the storm drain sewer)</li> </ul> $F19 = \sum_{i=12}^{17} F_i \times \% \text{ to drains from each leakage}$ <p><b>+ F<sub>4</sub> × % to drains from uncollected waste</b></p>
F20	Plastic in storm drains to water systems	Plastic waste in storm drains which is not removed (as this plastic is assumed to be transported at some point in time to waterbodies if left uncollected).	<ul style="list-style-type: none"> <li>Plastic waste removed from storm drains and placed in a location that it will not re-enter at a later stage.</li> </ul> <p><b>F20 = F19 × % cleaned from storm drains</b></p>

<p><b>F21</b></p>	<p>Plastic retained on land</p>	<p>Plastic waste which remains indefinitely on land. For example, plastic entangled in vegetation, plastic isolated on land with no ability to enter water or drains, and plastic buried by residents. This also includes any plastic waste that originally was on land but has subsequently been collected by street sweeping activities.</p>	<ul style="list-style-type: none"> <li>Plastic waste at disposal facilities (these are included separately), waste which travels overland and eventually enters water or drains, or waste dumped in pit latrines that is eventually emptied to a location other than land.</li> </ul> $F21 = \sum_{i=12}^{17} F_i \times \% \text{ to land from each leakage}$ $+ F_4 \times \% \text{ to land from uncollected waste}$
<p><b>F22</b></p>	<p>Openly burnt plastic waste</p>	<p>Plastic waste which has or will at any point in time be openly burnt as a disposal method (i.e. burning of uncollected waste by residents, or burning of sorting rejects).</p>	<ul style="list-style-type: none"> <li>Plastic burnt by residents for fuel (as this is not considered as waste), or burning that occurs in dedicated facilities such as incinerators (as this is accounted for by the energy from waste flow).</li> </ul> $F22 = \sum_{i=12}^{17} F_i \times \% \text{ burnt from each leakage}$ $+ F_4 \times \% \text{ burnt from uncollected waste}$



## Annex 2: Example leakage assessment for transportation

Here we will outline an example assessment of the transportation vehicles within a municipality so as to guide users in how to perform these assessments.

For reference, the decision tree for the transportation is as follows:

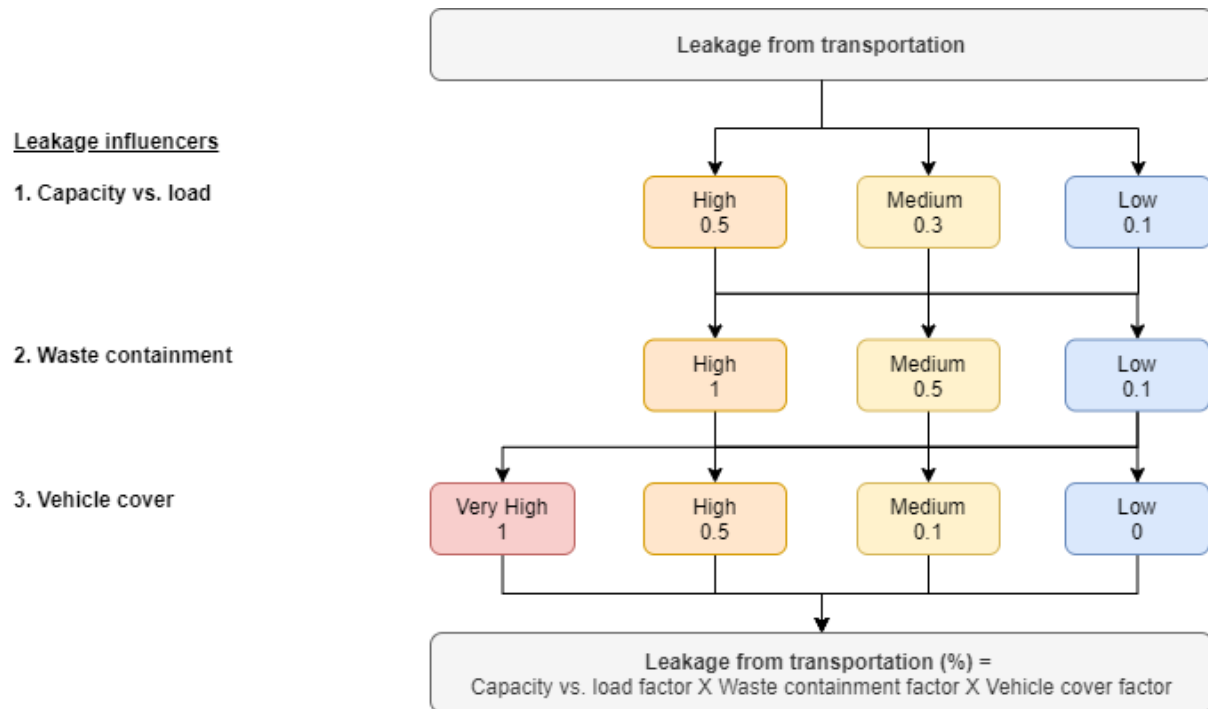

**Figure 23: Decision tree and calculation of leakages from Transportation**

It can be seen that there are 3 leakage influencers, (1) capacity vs. load, (2) waste containment, and (3) vehicle cover. Firstly, considering the first influencer, capacity vs. load, suppose observational assessments within the study area suggested that the majority of transportation vehicles looked like that shown in Figure 25, and are therefore clearly running over capacity. This is regardless of any subsequent cover as this is addressed later. Based on the observations the assessment would therefore be deemed to best fit the “high” leakage potential, as shown in Table 45

### Capacity vs load

**Table 45: Leakage potential levels for influencer “Capacity vs load”**

Leakage Potential	Description	Leakage Factor
<b>High</b>	<b>The load in most of the collection vehicles exceeds the capacity.</b>	<b>0.5</b>
<b>Medium</b>	Around half of the trucks’ load exceeds the capacity.	0.3
<b>Low</b>	The load in most of the collection vehicles does not exceed the capacity.	0.1



**Figure 24: Load exceeds the capacity of the truck. Plastics leak from this secondary collection vehicle in Kenya.**

*Waste containment*

For the second leakage influencer, “waste containment”, this addresses whether waste is generally disposed of in bags or left open. Alternatively, waste pickers who open bags on the transportation vehicle to pick valuable materials are also considered here. Assuming that during the assessment you observed the majority of the transportation vehicles looked like that of Figure 25a, with waste being transported in bags, you would choose the “low” leakage potential as shown in Table 46. Alternatively, if the majority of the transportation vehicles looked similar to that of Figure 25b, with no waste being stored in bags, you would choose the “high” leakage potential as shown in Table 46.



**Figure 25: Collection vehicles carrying a) contained waste and b) uncontained waste**

**Table 46: leakage potential levels for influencer “Waste containment”**

Leakage Potential	Description	Leakage Factor
<b>High</b>	Most of the generators in the city do not dispose of their waste contained in bags. Loaders practice cherry picking during transport for which they open most of the bags.	1
<b>Medium</b>	Around half of the generators in the city dispose of their waste contained in bags and the other half uncontained. Loaders practice some cherry picking during transport for which they open some of the bags.	0.5
<b>Low</b>	Most of the generators in the city dispose of their waste contained in bags and these are not opened during transport.	0.1

*Coverage of collection vehicle*

For the third leakage influencer, “coverage of collection vehicle”, this addresses whether the transportation vehicle is covered or not. Assuming that during the assessment you observed the majority of the transportation vehicles looked like that of Figure 26a, with transportation vehicles having no form of cover, you would choose the leakage potential of “very high” as shown in Table 47. Alternatively, if the majority of the transportation vehicles were fully enclosed, such as that in Figure 26b, you would choose the “low” leakage potential as shown in Table 47.



**Figure 26: Collection vehicles carrying a) contained waste and b) uncontained waste**

**Table 47: leakage potential levels for influencer “Coverage of collection vehicle”**

Leakage Potential	Description	Leakage Factor
<b>Very high</b>	Most of the collection vehicles in the city are uncovered vehicles	1
<b>High</b>	The number of collection vehicles are fairly split between uncovered and fully enclosed.	0.5
<b>Medium</b>	Most of the collection vehicles in the city are fully enclosed.	0.1
<b>Low</b>	All of the collection vehicles in the city are fully enclosed (e.g. compactor trucks)	0

### Annex 3. Levels of control for solid waste management facilities

CONTROL LEVEL	Landfill site <i>(all conditions of the precedent level need to be met to categorize for a given level)</i>			Incineration with energy recovery	Other recovery facilities <i>(all conditions of the precedent level need to be met to categorize for a given level)</i>		
	Access	Control waste management	Env./health		Formality and access	Performance	Env./health
Full	<input type="checkbox"/> No waste pickers	<input type="checkbox"/> Daily cover <input type="checkbox"/> Site and cell planning <input type="checkbox"/> Post closure plan	<input type="checkbox"/> Leachate treatment (constructed liner) <input type="checkbox"/> Gas utilisation and/or flaring <input type="checkbox"/> Environmental monitoring and reporting	<input type="checkbox"/> Built to and operating in compliance with an international best practice including e.g. EU or other similarly stringent stack and GHG emission criteria <input type="checkbox"/> Emission controls are conducted compliant to environmental standards <input type="checkbox"/> Fly ash managed as a hazardous waste using the best appropriate technology. <input type="checkbox"/> Weighing and recording conducted <input type="checkbox"/> A strong and robust environmental regulator who inspect and monitor emissions	<input type="checkbox"/> N/A	<input type="checkbox"/> Built to and in compliance with international best practice <input type="checkbox"/> The nutrient value of biologically treated materials utilized (e.g. in agriculture/horticulture) <input type="checkbox"/> Materials extracted with high purity and delivered into recycling markets	<input type="checkbox"/> Pollution control compliant to environmental standards
Improved Control	<input type="checkbox"/> Access roads on the site always accessible <input type="checkbox"/> Implemented monitoring and reporting plan of amounts disposed <input type="checkbox"/> Controlled/permitted access to waste pickers	<input type="checkbox"/> Regular compaction <input type="checkbox"/> Irregular cover	<input type="checkbox"/> Leachate containment <input type="checkbox"/> Gas collection <input type="checkbox"/> Litter fence <input type="checkbox"/> PPE and health checks to workers	<input type="checkbox"/> N/A	<input type="checkbox"/> N/A	<input type="checkbox"/> Engineered facilities with effective process control <input type="checkbox"/> Evidence of materials extracted being delivered into recycling or recovery markets.	<input type="checkbox"/> N/A
Basic Control	<input type="checkbox"/> Weighbridge <input type="checkbox"/> Access to site always clear	<input type="checkbox"/> Placement plan and tipping face <input type="checkbox"/> Irregular compaction	<input type="checkbox"/> No fires <input type="checkbox"/> Rainwater drainage	<input type="checkbox"/> Emission controls to capture particulates <input type="checkbox"/> Trained staff follow set operating procedures <input type="checkbox"/> Equipment maintained	<input type="checkbox"/> Registered facilities <input type="checkbox"/> Clear designated boundaries	<input type="checkbox"/> N/A	<input type="checkbox"/> Provisions made for worker health and safety

		<input type="checkbox"/> Appropriately staffed		<input type="checkbox"/> Ash management carried out Weighing and recording conducted			<input type="checkbox"/> Some environmental pollution control
Limited Control	<input type="checkbox"/> Clear designated boundary <input type="checkbox"/> Fence or similar <input type="checkbox"/> Gate	<input type="checkbox"/> Few staff <input type="checkbox"/> Equipment for moving and spreading	<input type="checkbox"/> None	<input type="checkbox"/> N/A	<input type="checkbox"/> Unregistered facilities <input type="checkbox"/> Clear designated boundaries	<input type="checkbox"/> Weighing and recording conducted	<input type="checkbox"/> None
No Control	<input type="checkbox"/> None	<input type="checkbox"/> None	<input type="checkbox"/> None	<input type="checkbox"/> Uncontrolled burning <input type="checkbox"/> No air/water pollution control functions	<input type="checkbox"/> Unregistered locations <input type="checkbox"/> No distinguishable boundaries	<input type="checkbox"/> None	<input type="checkbox"/> None



## References

- EUNOMIA 2016. *Plastics in the marine environment*. Bristol.
- GEYER, R., JAMBECK, J. R. & LAW, K. L. J. S. A. 2017. Production, use, and fate of all plastics ever made. *Science Advances*, 3, e1700782.
- KAZA, S., YAO, L., BHADA-TATA, P. & WOERDEN, F. V. 2018. *What a Waste 2.0: A Global Snapshot of Solid Waste Management to 2050. Urban Development Series*. Washington, DC: World Bank.
- LAW, J. & APPELQVIST, B. 2019. *Landfill Operational Guidelines 3rd Edition. A report from ISWA's Working Group on Landfill 2019*. ISWA.
- MARTEL, C. & HELM, R. J. W. M. W. 2004. Prevention, control and collection-techniques for managing landfill litter. 57-62.
- SCHEINBERG, A., SIMPSON, M., GUPT, Y., ANSCHÜTZ, J., HAENEN, I., TASHEVA, E., HECKE, J., SOOS, R., CHATURVEDI, B. & GARCIA-CORTES, S. 2010. Economic aspects of the informal sector in solid waste management. *GTZ and CWG, Eschborn, Germany*.
- UN-HABITAT 2020. *Waste Wise Cities Tool: SDG 11.6.1. A step-by-step guide for a rapid assessment of SWM systems in cities*. <https://unhabitat.org/waste-wise-cities-campaign>
- WILSON, D. C., RODIC, L., MODAK, P., SOOS, R., CARPINTERO, A., VELIS, K., IYER, M. & SIMONETT, O. 2015. *Global waste management outlook*, UNEP.